

Simple Free-Energy Devices

There is nothing magic about free-energy and by “free-energy” I mean something which produces output energy without the need for using a fuel which you have to buy.

Chapter 33: The Simplified Perpetual Light

There has already been shown a Perpetual Light system where lighting batteries are recharged when the light is not in use. That design uses a latching relay to swap between two batteries on a continuous basis, but that tends to confuse some people and make the design seem too complicated. So, here is a design from our South African developer friend who shares his work freely and generously. He has daily mains power cuts which average seven hours per day and that brings into play the old saying that “necessity is the mother of invention”.

He has built some of the earlier light design which uses a latching relay and those work very well, this one uses a tiny 12V to 220V inverter and a mains LED bulb:

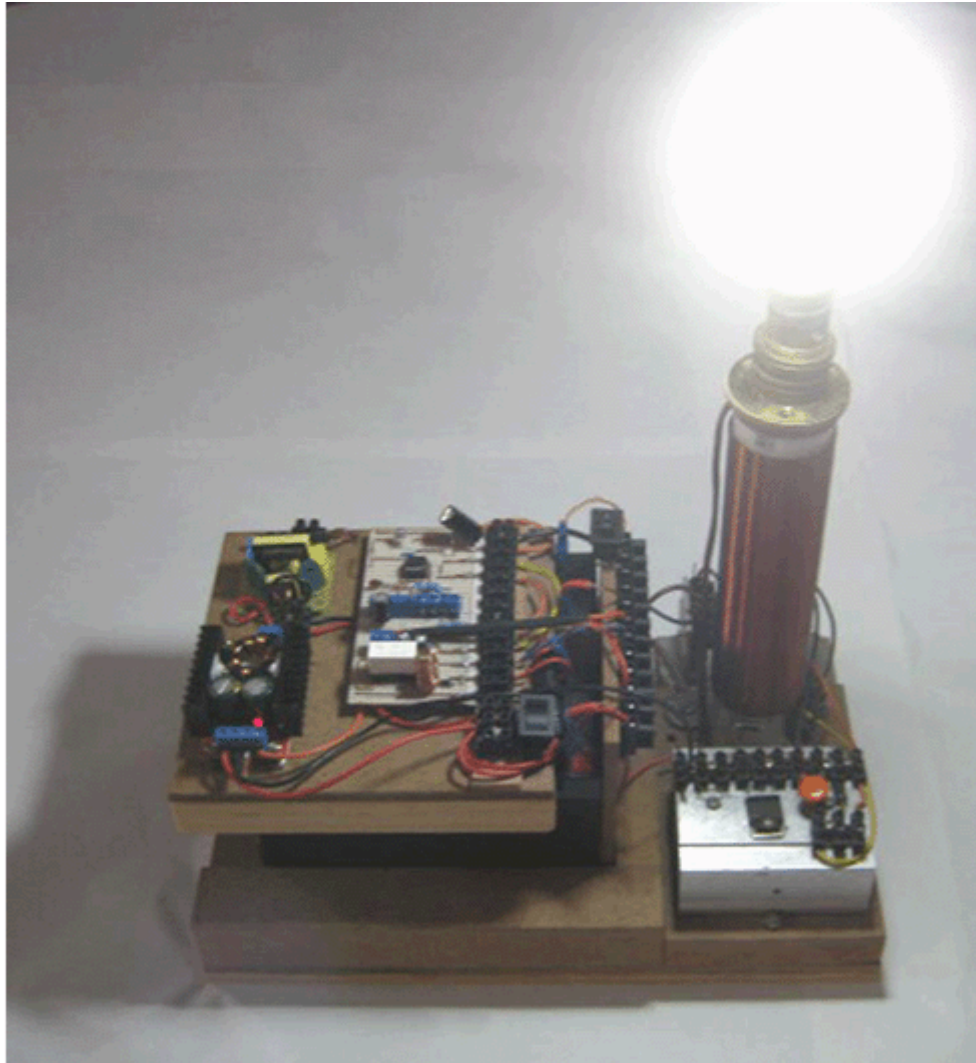

However, looking for an even more simple version has led to the following design which has few components and yet which works very well:

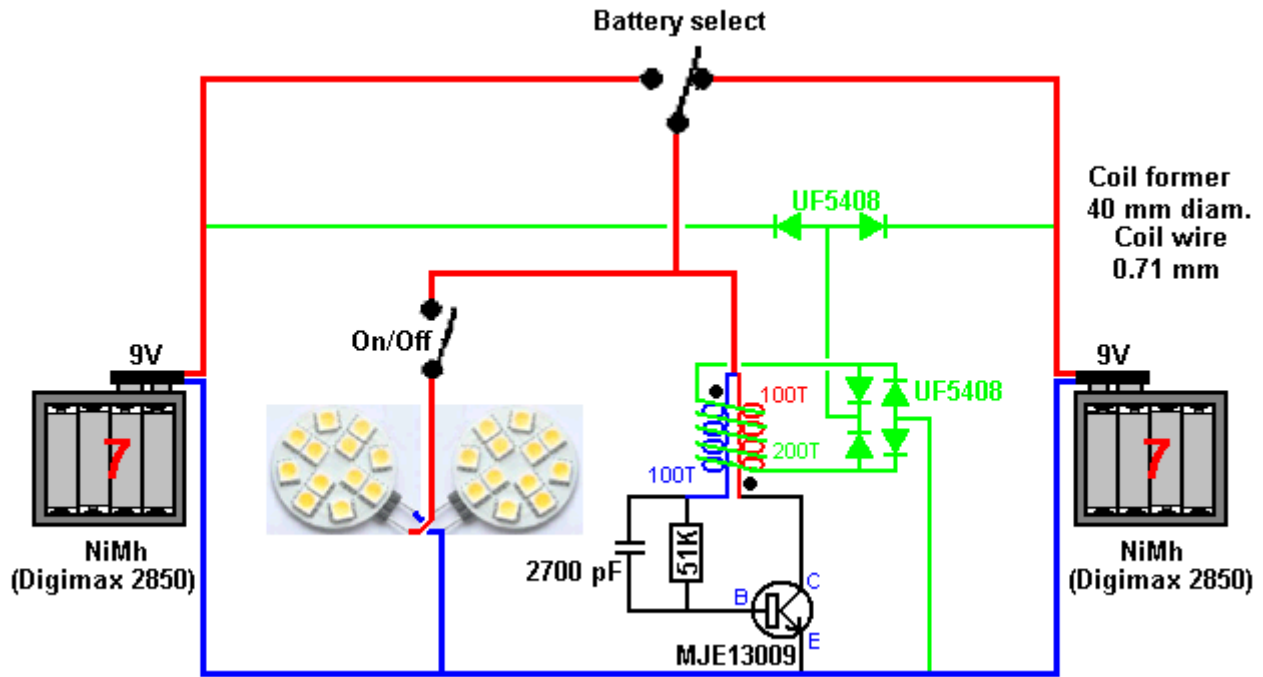

As in the photograph above, the coil is wound on a white plastic pipe which has an outer diameter of forty millimeters. This is a modified Joule Thief circuit so the coil is started by winding two strands of 0.71 mm diameter enamelled solid copper wire. These wires are wound side by side (shown in red and blue in the diagram above). Each wire has 100 turns in this winding which places two hundred turns side by side on the pipe. If wound perfectly, 200 turns of 0.71 mm wire will cover a 142 millimeter length of the pipe, that is 5.6 inches. However, we need some spare space at each end of the coil, so we will need about 170 mm or 6.5 inches of pipe to make the coil. The length of wire in each of these two strands is about 13 metres, that is just under 50 grams in each strand.

Having wound these first two strands of wire to form the Joule Thief bi-filar coil, we now wind a second coil on top of the bi-filar coil, using the same diameter wire. This coil is 200 turns of wire wound side by side in a single helix. This coils is shown in green in the above circuit diagram and requires about 26 metres of wire, that is just under 100 grams of wire. When winding a coil, always remember to leave sufficient length at each end of the coil to be able to make the circuit connections afterwards..

The circuit is very simple, being just two LED arrays providing 160 degree wide lighting when powered by a battery:

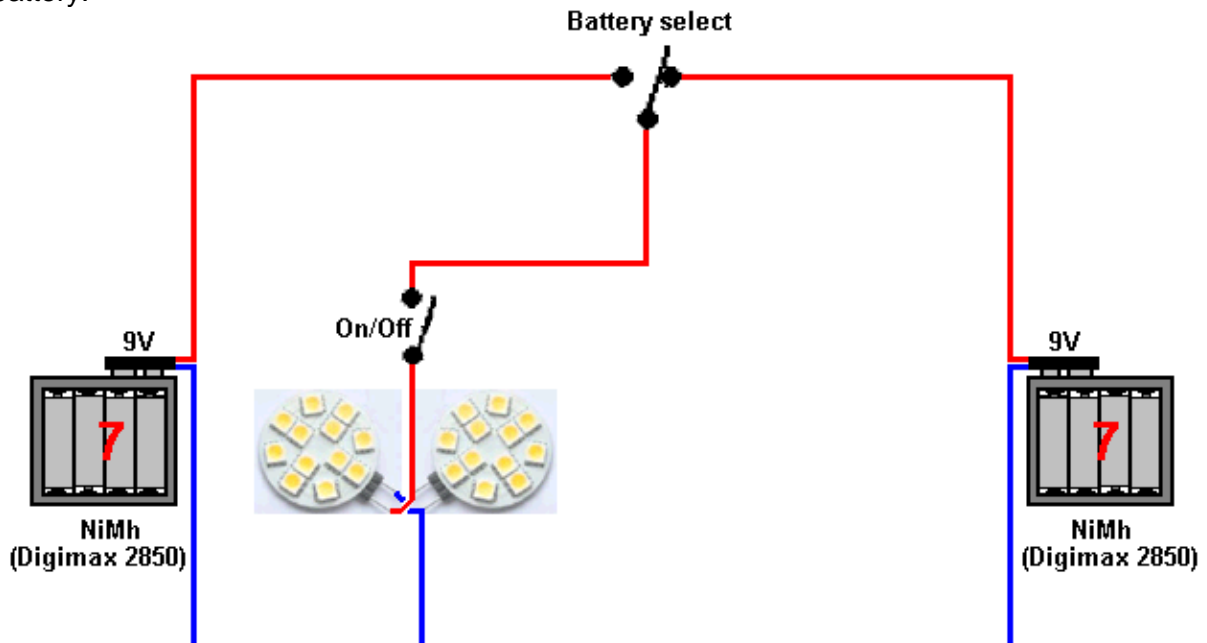

With this arrangement either battery can be selected by the top switch and the light turned on or off using the lower switch. However, it is important to select the right components for every part of this circuit. AA size batteries are used. The batteries chosen are important because there is an enormous difference in battery performance when tested under an actual load, so pick Digimax 2850 batteries:



Digimax 2850

Fourteen of these batteries are needed in order to have two sets of seven batteries in a slightly adapted battery box:



Tests have shown that seven AA size batteries produce about nine volts and a 12-volt LED array draws only 33 milliamps of current and produces 209 lux of light at that tiny current draw. So using two of these LED arrays will draw about 66 milliamps and provide 418 lux of wide-angle lighting which one set of batteries can sustain for more than fifteen hours.

However, that is not what we want to do. Instead we also power the adapted Joule Thief circuit and use it to recharge both batteries all of the time. However, a battery which is not providing current to a load, recharges much better than a battery which is providing current. You can, of course, switch the current draw from one set of batteries to the other, any time that you choose to do so, but let me stress that the circuit components shown here are important and you should not substitute alternatives as these components work well.

We live in a massive energy field and we recharge the batteries by persuading that energy field to do it for us. This is accomplished by producing a series of voltage spikes. Those voltage spikes disturb the energy field and as it settles back down it feeds energy into our circuit. Please understand very clearly that the battery recharging is NOT done by the voltage spikes themselves but instead of that it is the inflow of energy from the surrounding energy field which does the recharging. The recharging is greatest if the voltage spikes switch off suddenly (and to a lesser extent switch on suddenly). For this, we use diodes which have a fast action, in this case UF5408 diodes as the "UF" stands for Ultra Fast.

Take a look at the circuit:

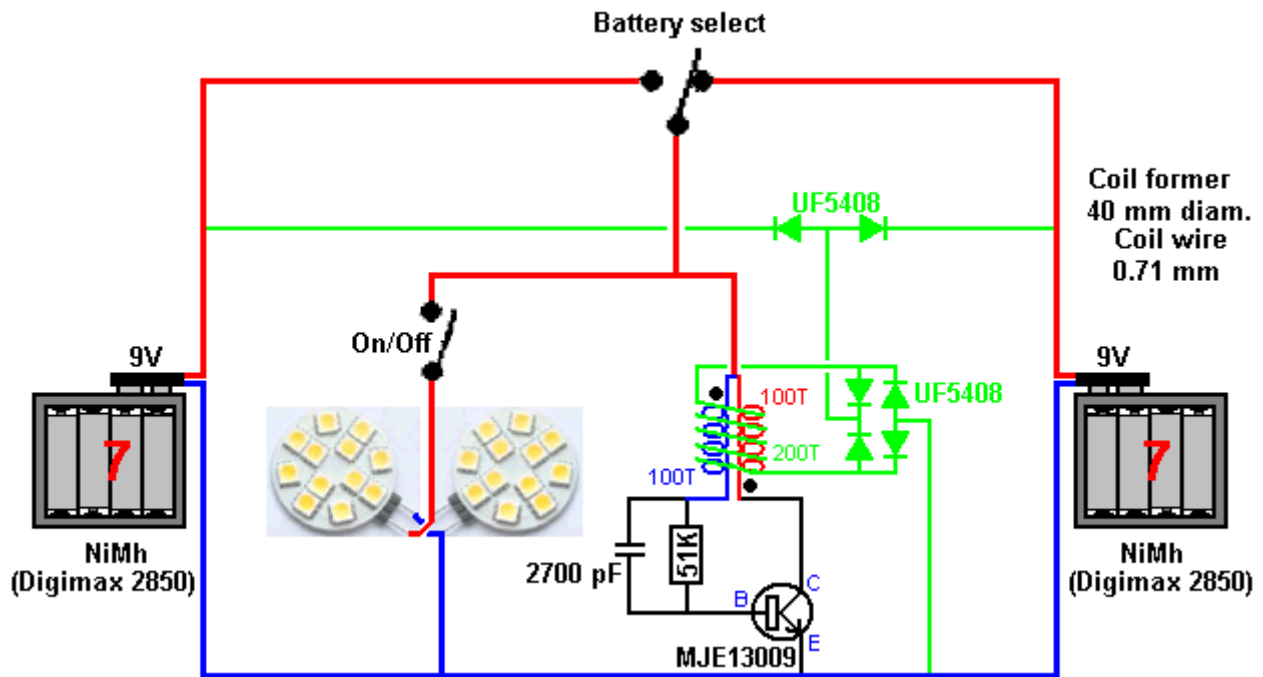

The best performance is when the transistor is a T13009 which is also sold under the name MJE13009. The 2700 pF capacitor is important as is the value of the 51K resistor. If you generally use the more basic series of resistors, then a 51K resistor can be a 47K resistor and a 3.9K resistor in series. The bridge of four UF5408 diodes can be replaced by an RS405L diode bridge if you prefer.

Patrick J Kelly
www.free-energy-info.tuks.nl
www.free-energy-info.com
www.free-energy-info.co.uk