

# Simple Free-Energy Devices

There is nothing magic about free-energy and by “free-energy” I mean something which produces output energy without the need for using a fuel which you have to buy.

## Chapter 3: The FLEET Circuit

Lawrence Tseung modified the Joule Thief circuit of chapter 2 by adding an additional winding to it. This extra winding is made with two strands of wire laid side by side. Also, the ferrite ring of the Joule Thief is replaced with a much larger plastic ring, and the wire used to wind the coils is increased to normal household size. The modified circuit looks like this:

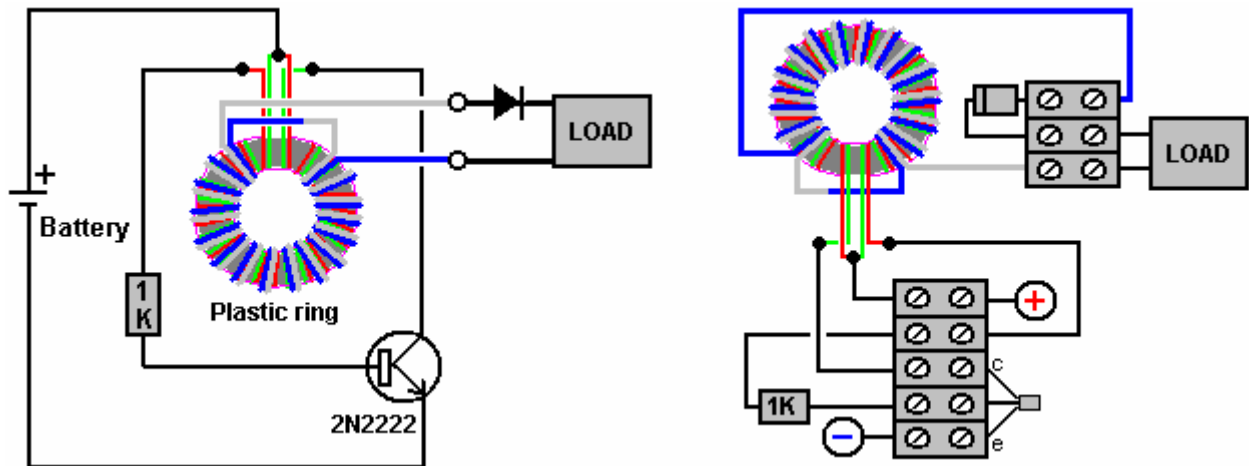

Lawrence calls this circuit the “FLEET” circuit and he has tried it with many different coils:



This circuit oscillates at about 280,000 times per second and the waveform is like this:

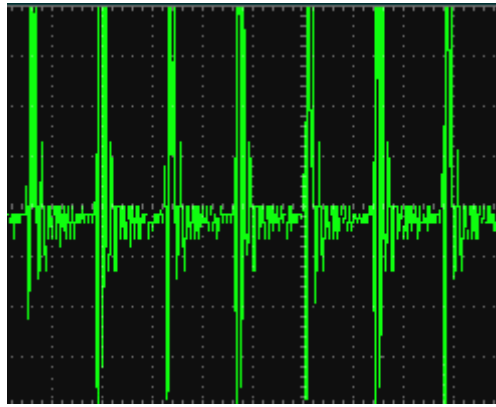

Some years ago there was some heated discussion about whether or not free-energy actually existed. There was no doubt in my mind, but in spite of that I wound a plastic ring of about 200 mm in diameter and set up a FLEET circuit in one evening. I ran the circuit with two identical small, 12V lead-acid batteries, one to power the circuit and one to be charged by the circuit. I used a diode bridge of four diodes rather than just a single diode. This is the circuit:

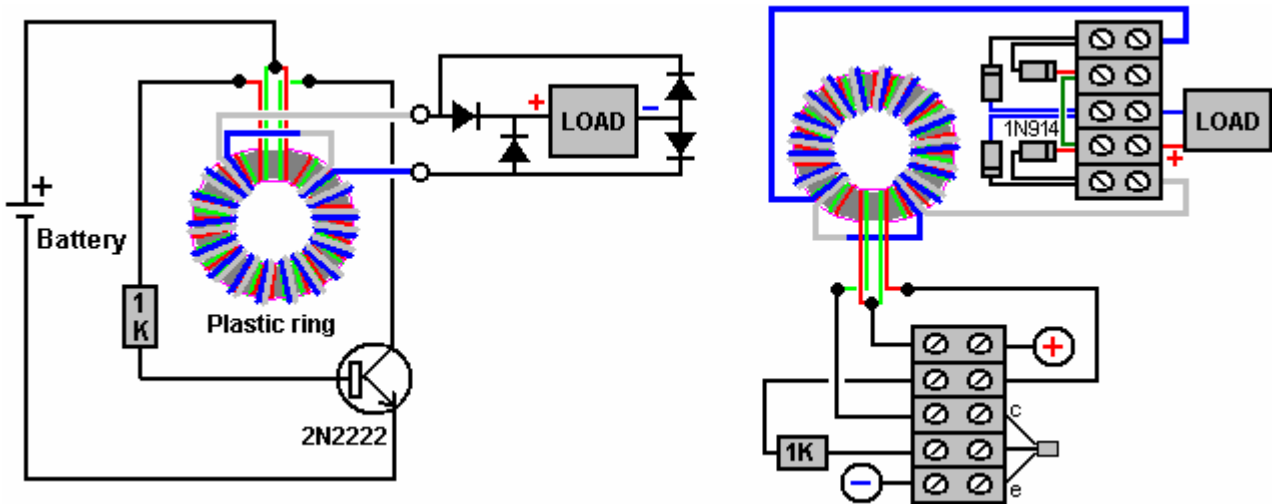

And this is the coil which I used:

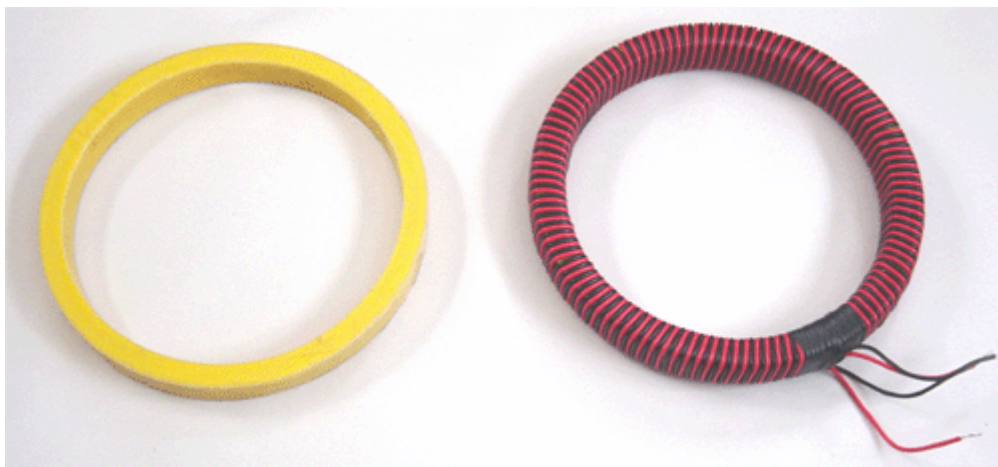

The objective was to have no outside source of power. I may have used a higher value base resistor but I do not recall if I did. The results were most revealing. I ran the circuit for some hours, swapped the batteries over and repeated the charging. Then the batteries were swapped over again and a third charging period was performed. At the end of those tests, both batteries had greater, real, usable

power than when the test was started. That certainly convinced me that power was flowing into the circuit from outside.

There is also the fact that lead-acid batteries are only 50% efficient, that is, they lose half of the current which you feed into them. The fact that both batteries gained power shows clearly that the FLEET circuit performed for me by outputting more than twice the power needed to make it run.

Patrick J Kelly

[www.free-energy-devices.com](http://www.free-energy-devices.com)