

Simple Free-Energy Devices

There is nothing magic about free-energy and by “free-energy” I mean something which produces output energy without the need for using a fuel which you have to buy.

Chapter 23: Power From Inertia

Chas Campbell's Flywheel System.

Recently, Mr. Chas Campbell of Australia demonstrated electrical power gain with a flywheel system which he developed. Essentially, he spins a mains motor, gears it appropriately through a drive train which includes a ten kilogram flywheel so that it spins an AC generator at its optimum speed of just over three thousand revs per minute. When the system is running at full speed, Chas switches the mains motor over so that it is powered by the output of the generator. This works very well and allows his self-powered system to power other tools like drills. This is the arrangement:

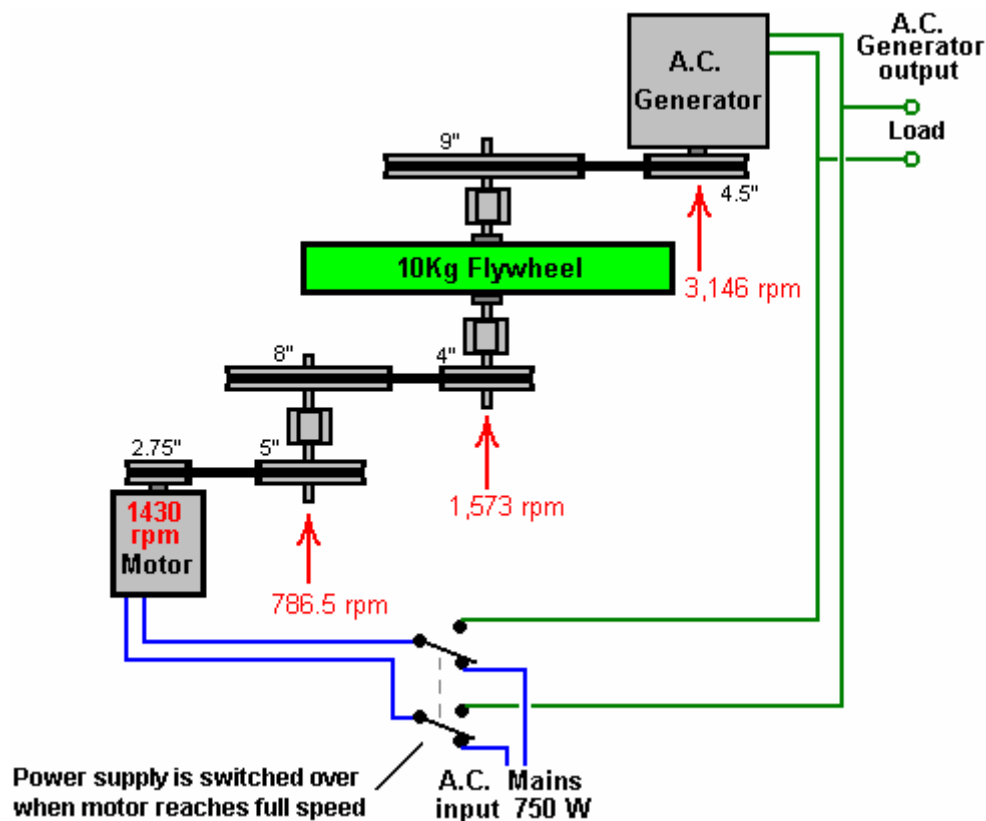

Let me explain the overall system. A mains motor of 750 watt capacity (1 horsepower) is used to drive a series of belts and pulleys which form a gear-train which produces over twice the rotational speed at the shaft of an electrical generator. The intriguing thing about this system is that greater electrical power can be drawn from the output generator than appears to be drawn from the input drive to the motor. How can that be? Well, although it does not appear to be widely known, the rim of a rotating flywheel is considered to be continuously accelerating inwards towards the axle. That constant acceleration produces an inflow of energy from the gravity field into the system. The important point is that Chas Campbell's system is self-powered and can power other equipment as well.

Now take a look at the construction which Chas has used:



You notice that not only does he have a heavy flywheel of a fair size, but that there are three or four other large diameter discs mounted where they also rotate at the intermediate speeds of rotation. While these discs may well not have been placed there as flywheels, nevertheless, they do act as flywheels, and each one of them will be contributing to the free-energy gain of the system as a whole. A video of a neat replication, with 750 watts input power and 2340 watts of output power is here: <http://www.youtube.com/watch?v=98aiSB2DNw> and this implementation does not appear to have a heavy flywheel as you can see from this picture, although the largest pulley wheel looks as if it contains considerable weight:

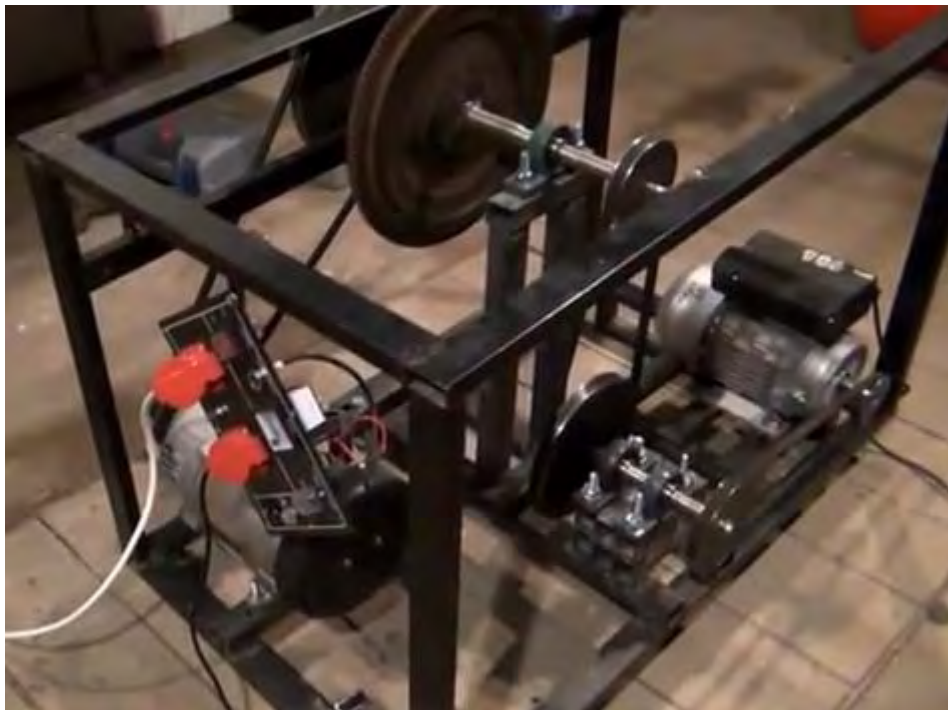

Jacob Byzehr's Analysis.

In 1998, Jacob lodged a patent application for a design of the type shown by Chas Campbell. Jacob has analysed the operation and he draws attention to a key design factor:

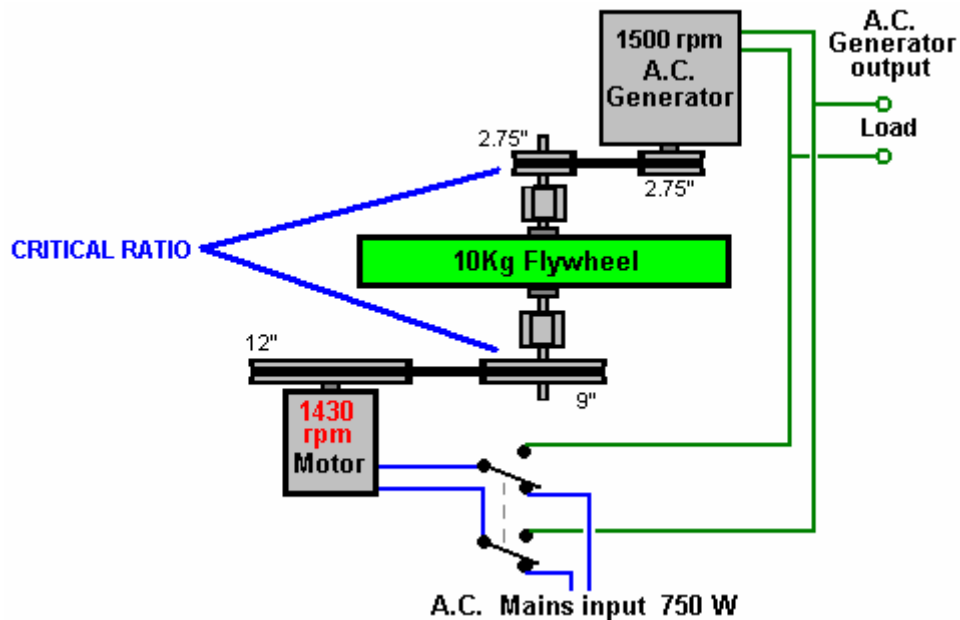

Jacob states that a very important feature for high performance with a system of this kind is the ratio of the diameters of the driving and take-off pulleys on the shaft which contains the flywheel, especially with systems where the flywheel rotates at high speed. The driving pulley needs to be three or four times larger than the power take-off pulley. Using Chas' 1430 rpm motor and a commonly available 1500 rpm generator, the 12:9 step-up to the shaft of the flywheel gives a satisfactory generator speed while providing a 3.27 ratio between the 9-inch diameter driving pulley and the 2.75" diameter power take-off pulley. If a generator which has been designed for wind-generator use and which has its peak output power at just 600 rpm is used, then an even better pulley diameter ratio can be achieved.

Patrick J Kelly

www.free-energy-info.tuks.nl

www.free-energy-info.com

www.free-energy-devices.com