

# *Simple Free-Energy Devices*

There is nothing magic about free-energy and by “free-energy” I mean something which produces output energy without the need for using a fuel which you have to buy.

## *Chapter 16: The Shigeta Hasebe Electrolyser*

In August 1978, Shigeta Hasebe was granted US Patent 4,105,528 for an electrolyser design. The gas production from his DC cell was seven litres of HHO per minute for an input power of just 84 watts using a Sodium Hydroxide electrolyte.

The cell consists of two coiled electrodes with spacers every quarter turn:

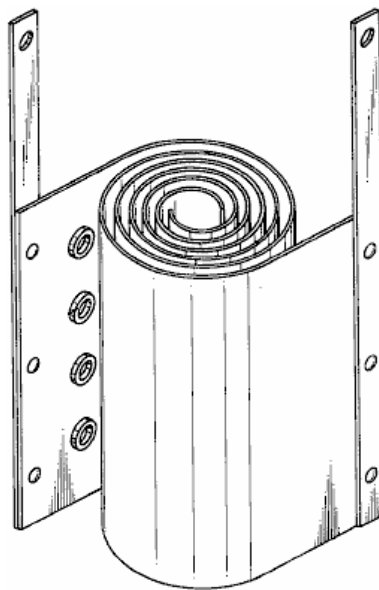

These electrodes are surprisingly difficult to make by hand but they should be very simple to construct using a 3D printer. These electrodes are then bolted to a non-conducting enclosure:

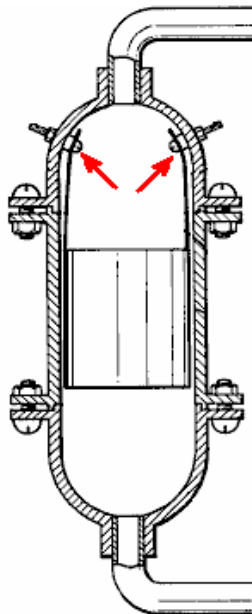

Next, two powerful permanent magnets are mounted in the container, one above the electrodes and one below them:

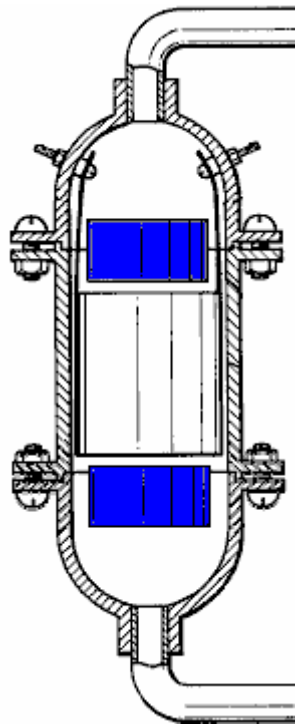

Looking down on the magnets and electrodes they look like this:

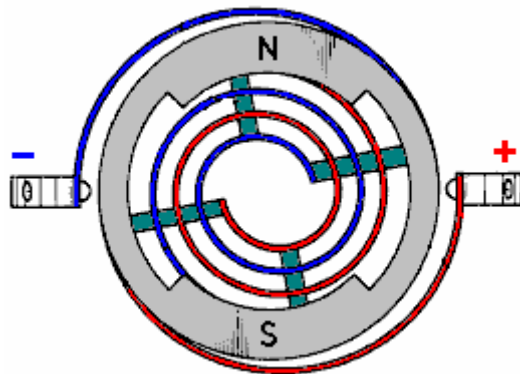

The magnets are arranged to produce a magnetic field which runs across the axis of the electrolyser. The spacers (shown in green) are not continuous but are quite separate, and they are there to cause turbulence as well as to force the desired electrode spacing:

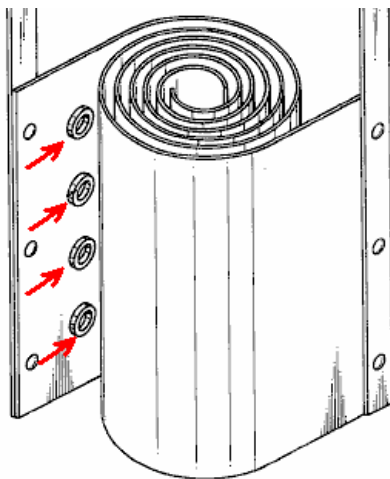

The electrolyser is connected directly to a reservoir of electrolyte and a pump is used to circulate the electrolyte which brushes bubbles off the electrodes:

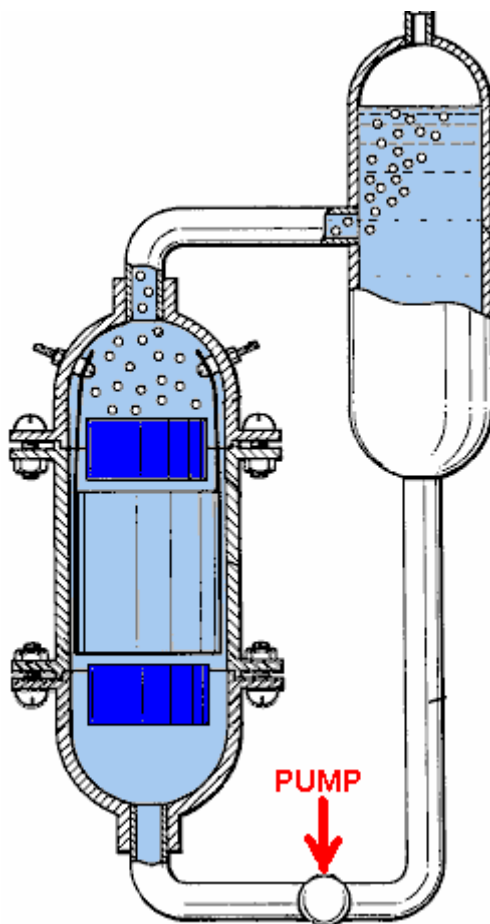

The output pipe of the electrolyser is connected to the side of the electrolyte reservoir and there, the bubbles float upwards and exit through a bubbler while the remaining electrolyte gets circulated again by the pump.

The test results from this design were 7 litres of HHO gas per minute from just 84 watts of input power. The input power was 30 amps from a 2.8 volt power supply. Consequently, it should be possible to run four of these cells from a 12-volt supply which is a commonly used voltage. Alternatively, two of these cells could be run from a 6-volt supply if that is what is available:

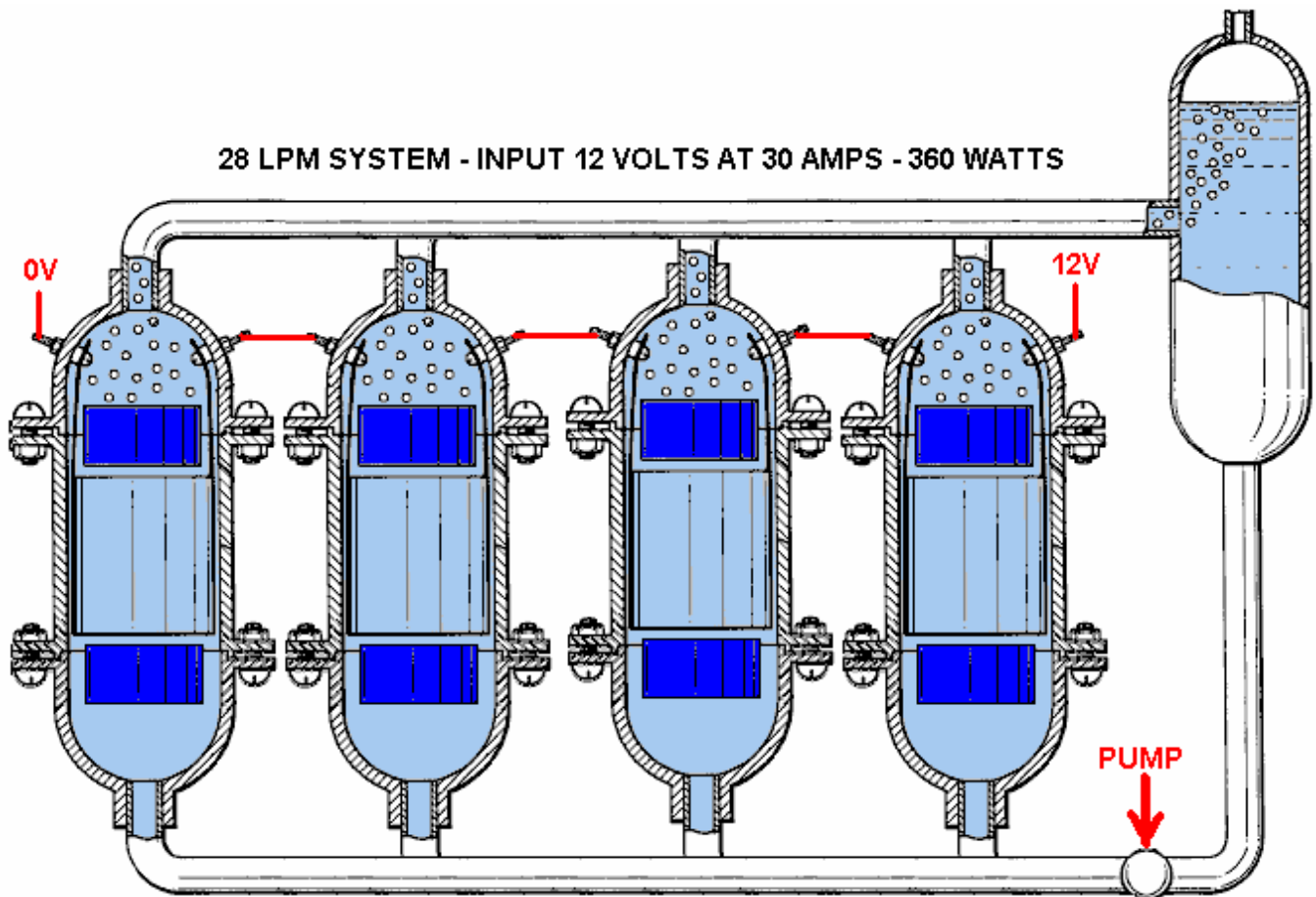

An alternative nowadays would be to run just one cell using a cheap DC-to-DC step-down converter as a standard generator has great deal of spare electrical capacity. A generator running on HHO only needs about 5 litres per minute of HHO to provide kilowatts of excess power to run a household.

It is probably worth remarking that this generator design produces about ten times the HHO output that Michael Faraday considered to be the maximum possible. However, Shigeta was disappointed by the performance as his calculations showed that he could expect twice the gas volume that he was actually getting.

In passing, Bob Boyce of America has produced an electrolyser system which produces 100 litres of HHO per minute. With that rate of gas production, it is a major challenge to get the gas out of the electrolyser while leaving the electrolyte behind. The efficiency of Bob Boyce's electrolyser is about twelve times that of Faraday's presumed maximum.

Patrick J Kelly  
[www.free-energy-info.co.uk](http://www.free-energy-info.co.uk)