



Steve Ryan on 60 Minutes



<http://www.youtube.com/watch?v=POJQKg9CRJc>



Cavitating Electrolyzers The Key to “Over Unity”

Moray B King



HHO Device to ZPE Device

Cavitate the Water

Circulate the Water



HHO Device to ZPE Device

Cavitate the Water

Activates/Coheres Zero-Point Energy

Circulate the Water

Creates Turbulence

Electrostatic Charging

Builds Up Energy Content



Featured Inventor: Mark LeClair

Mechanical Engineer

Fluid Dynamics – Cavitation

Element Transmutation Experiment

Microscopic Water Crystal

Extraordinary Energy Density- ZPE

<http://nanospireinc.com/>



LeClair's Water Crystal Similarities

- Ken Shoulder's
 - EV Electrum Validum
 - EVO Exotic Vacuum Object
- S.V. Adamenko's
 - Plasmoid Strikes
 - Super-Nucleosynthesis
- **All Exhibit Element Transmutation**



Explain Brown's Gas

Excess Energy Anomalies

Not from Burning Hydrogen

Charged Water Gas Cluster:

LeClair's Microscopic Water Crystal
Stabilized in a Ring Form



Water as Fuel (via ZPE)

Sterling Allan



[Play](#)

[http://peswiki.com/index.php/Video:Water as Fuel \(via ZPE\)](http://peswiki.com/index.php/Video:Water as Fuel (via ZPE))

HHO Games



HHO Games & Exposition, Inc.

A Florida Non-Profit Educational Organization
PROUDLY PRESENTS

2010 HHO SUMMER GAMES

<http://hhogames.com/>



YouTube: Water Fuel

Over 41,000 Videos

YouTube  [Browse](#) | [Movies](#)

Filter ▾ About 41,600 results



Richard Chapman
3:24

Chevron Technology Video
Chevron Is Using Steamflooding to Extend the Oil Supply. Watch Video.
by Chevron | 14,815 views



1:29

PEM Electrolyser on sale - Start creating pure hydrogen gas
Visit www.H2Sunlight.com
by H2Sunlight | 50,131 views Ads



2:39

Water Fuel Car
A CAR THAT RUNS ON WATER!
by Hefeweizen | 6 years ago | 3,652,152 views



Eric Pk
2:56

Salt Water Fuel
An accidental discovery of salt **water fuel** while doing cancer research
by ChelseyTang | 5 years ago | 741,390 views



7:00

Water fuel .
This little engine has been retrofitted with a device that takes the waste heat from an engine and uses it to make hydrogen out of tap **water**. This ...
by eternalstarsurfer | 6 years ago | 1,127,827 views



March Labs

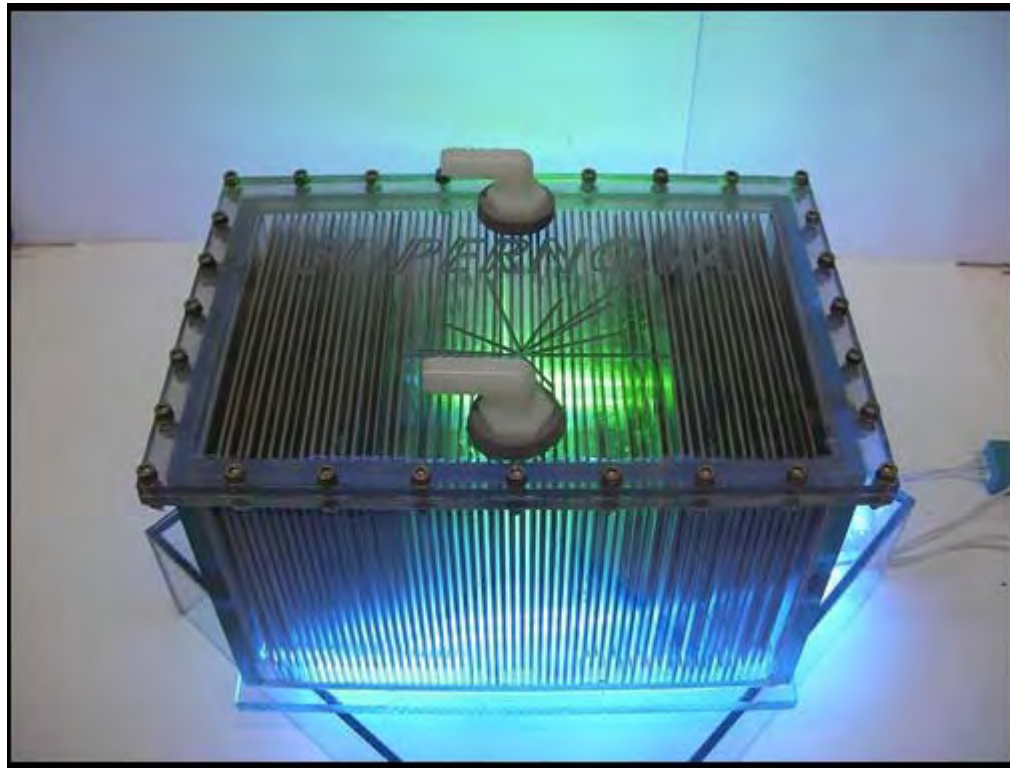

25 LPM, 110 V, 18 A

<http://www.marchlabs.com>

B.E.S.T. Korea Co., LTD



http://www.browngas.com/eng_bestkorea/main_eng.htm



Bob Boyce



70 Plates

3 mm gap



<http://www.bobbyoyce.org/>

[http://peswiki.com/index.php/OS:Bob Boyce Electrolyzer Plans](http://peswiki.com/index.php/OS:Bob_Boyce_Electrolyzer_Plans)

Dry Cell Kits



Gaskets Separate Plates



Anton Cell

1 mm
Gap



<http://anton-shop.com/>



Anton Cell Feeds Water at Bottom



<http://anton-shop.com/>



Electrolyzer Wiring

Typical Wet Cell

Plates Completely Immersed

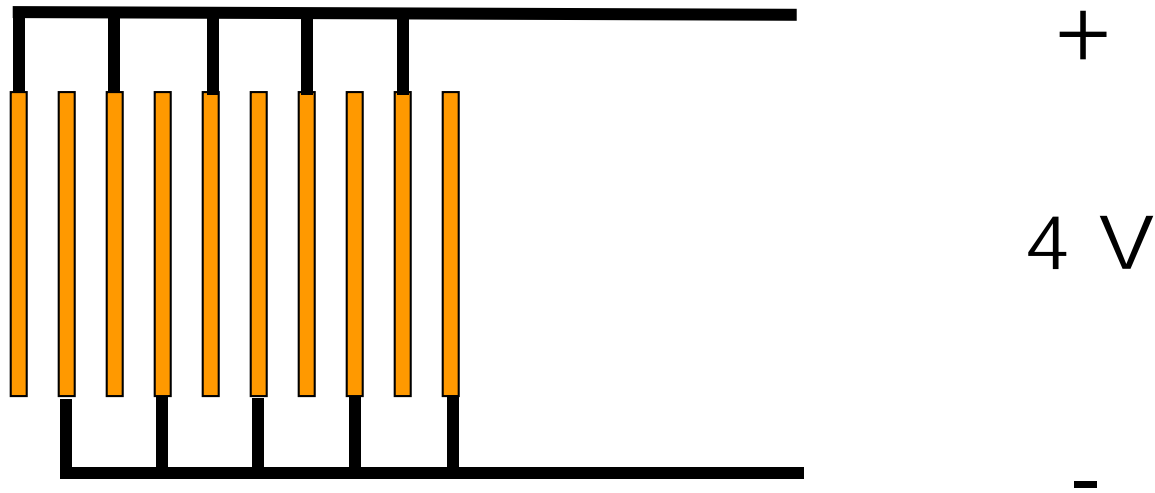

All Plates Connected



Electrolyzer Wiring

Typical Dry Cell

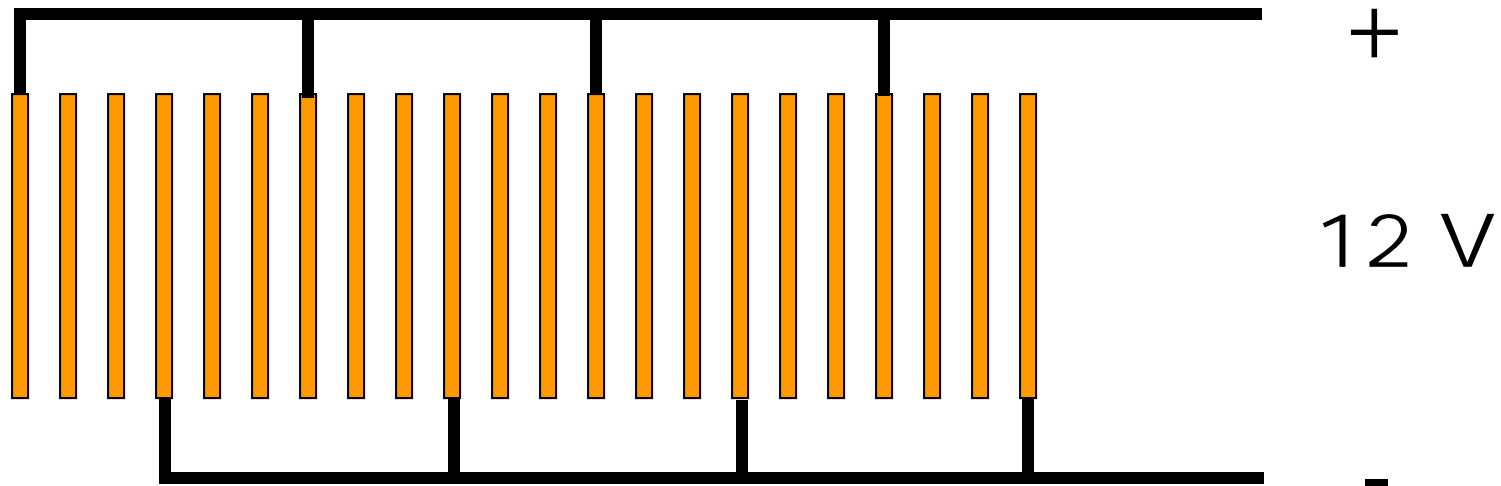

Floating plates are equipotential surfaces

Charged by electric polarization



Denny Klein in the News



[Play](#)

http://www.youtube.com/watch?v=6Rb_rDkwGnU



Nearly Everyone Believes

The Energy is from Hydrogen



Energy **Not** from Hydrogen

- **Big Anomalies:**
 - Cool Flame that Vaporizes Tungsten
 - Alters Radioactivity
 - Transmutation
- **Laboratory Analysis Find**
 - Little Hydrogen
 - Gaseous Charged Water Clusters



Source: **Zero-Point Energy**

- Charged Water Gas Clusters
- Similar to Plasma Charge Clusters
- Self-Organized Matter-ZPE Conglomerate
- Microscopic Ball Lightning

Ken Shoulders

- EV (Electrum Validum)
- EVO (Exotic Vacuum Object)



Ball Lightning Plasmoid

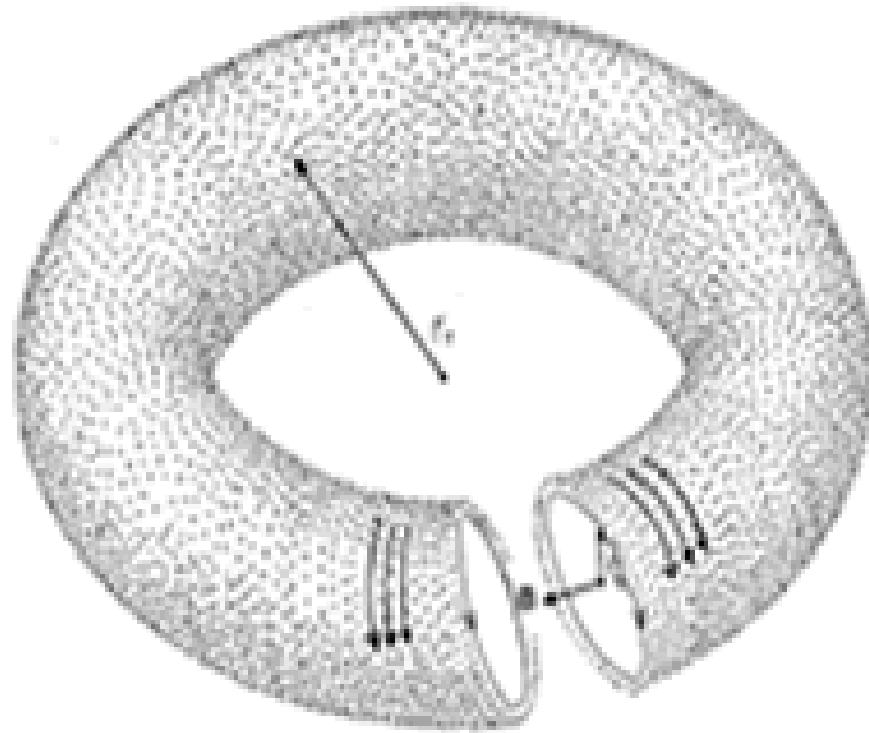

Electron Spiral Torus

<http://www.electronpowersystems.com/Technology>



Helical Flow in Plasmoid Vortex Ring Filament

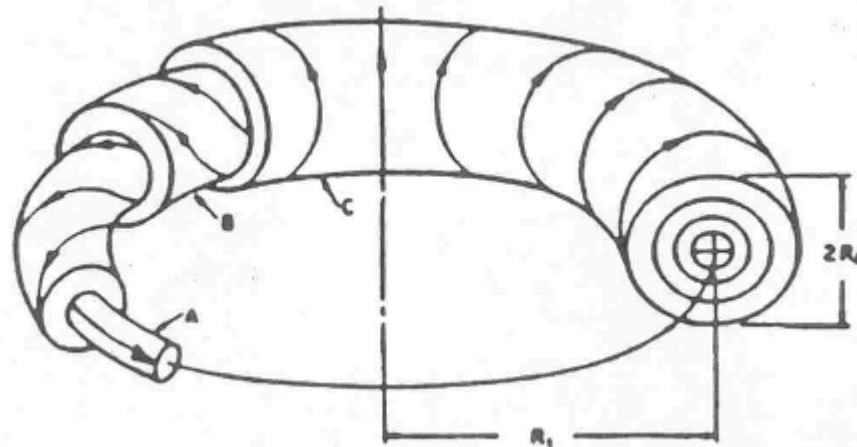

Force Free Vortex Yields Natural Stability

Alex, Radar, *Fusion Tech.* 27, 271 (1995)



Ken Shoulders Launching Charge Cluster

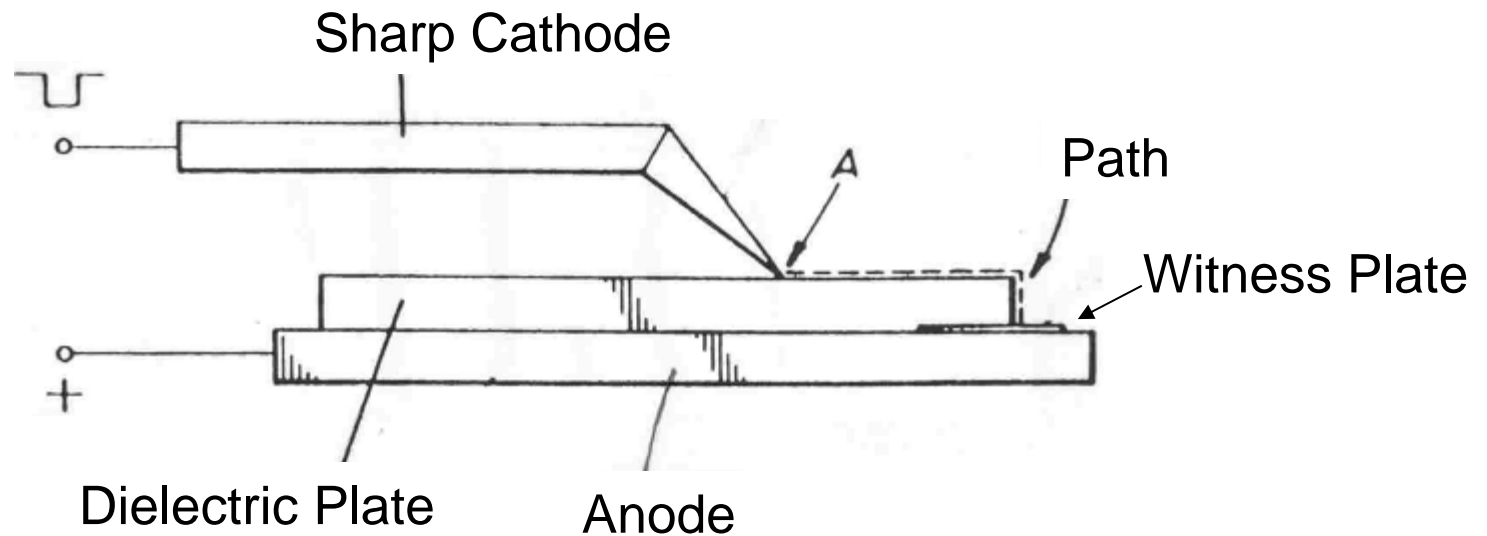

U.S. Patent 5,018,180 (1991)

<http://www.svn.net/krscfs>



Electrum Validum (EV) Exotic Vacuum Object (EVO)

10^{11} Electrons

10^6 Ions

e/m Ratio like electron

Contains excessive energy



Charge Cluster Anomalies

- Electrically Polarized: Adhere to dielectrics
- Clumps into “Necklace Formations”
- Bores holes in ceramics (aluminum oxide)
- Carves Trenches
- Disruption of electron bonds appears like melting
- Element Transmutation
- Radioactivity Reduction

Ken Shoulders, <http://www.svn.net/krscfs>



Plasma Charge Clusters & Charged Water Gas Clusters

Exhibit the **Same Anomalies**



Brown's Gas is Not Hydrogen Combustion

Energy is Stored in a Coherent Form



Cool Flame

130 deg C



[Play](#)

<http://www.youtube.com/watch?v=4wYY1V46YDQ>

Does Not Boil Water



[Play](#)

<http://www.youtube.com/watch?v=wK85QQPAuiU>

Vaporizes Tungsten



Melt 6192 deg F

Sublimate 10031 deg F

<http://www.youtube.com/watch?v=NQ0yQKI6M-Q>



Temperatures

Tungsten

| | | |
|----------|---------|--------|
| Melt | 6192 F | 3422 C |
| Vaporize | 10031 F | 5555 C |

Browns Gas **266 F** **130 C**

Torches

| | | |
|-----------------|--------|--------|
| Acetylene | 5972 F | 3300 C |
| Hydrogen arc | 7232 F | 4000 C |
| Cyanogen | 8477 F | 4525 C |
| Dicyanacetylene | 9009 F | 4987 C |



Burning Hydrogen Cannot Explain This

**Another Energetic Gas
is Present**

Empirical Evidence



Balloon Test

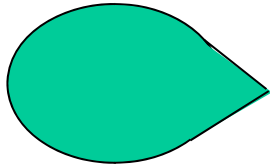

Fill balloon with gas

Wait, (hydrogen leaks away)

Balloon falls to ground



Still exhibits balloon torch



Paper Bag Test

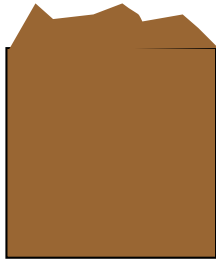

Fill paper bag with gas.

Seal bag shut.

Wait 12 hours, hydrogen vents away.

Open bag.

Heavier than air gas remains.

Gas can be ignited.



Glass Pouring Test

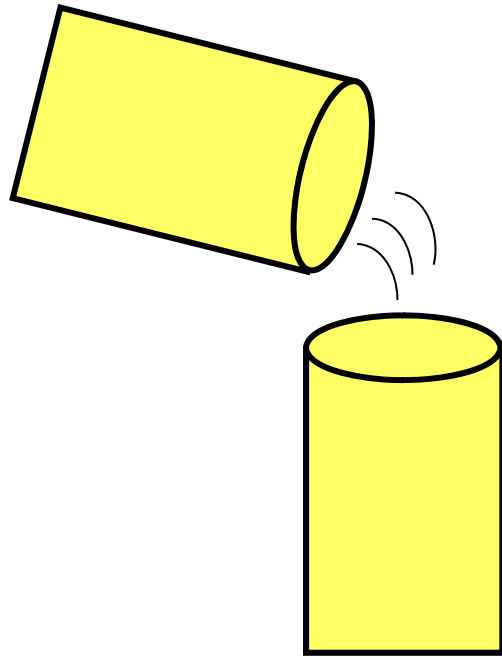

Gas is heavier than air.

It can be poured from one glass to another.

Ignite gas at bottom of glass.

George Wiseman

Electrically Expanded Water

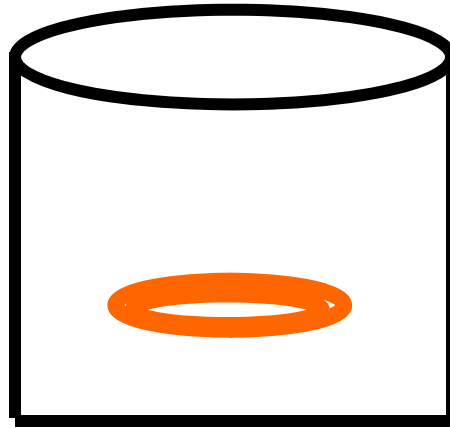

Burns downward in an imploding ring

http://pesn.com/2010/09/27/9501707_HHOi_under_pressure_into_fuel_rail_running_vehicles_on_water_and_air/



Action Item: Chemistry Departments

- Create Brown's Gas
- Vent Away the Hydrogen
- Does Remaining Gas "Burn?"
- What is it?



Brown's Gas Measurements

Chris Eckman

Electron Density (EDMA)

- Not Diatomic Hydrogen
- Not Monoatomic Hydrogen
- Gaseous Water with Excess Electrons

Thermal Imaging (InfraCAM SD)

- Flame Temperature 130 C (266 F)

Extraordinary Technology, vol. 2(6), pp 15-25, 2008



Brown's Gas Information



<http://eagle-research.com>



Wiseman: Middle Bubbles

**Charged Water
Gas Clusters**

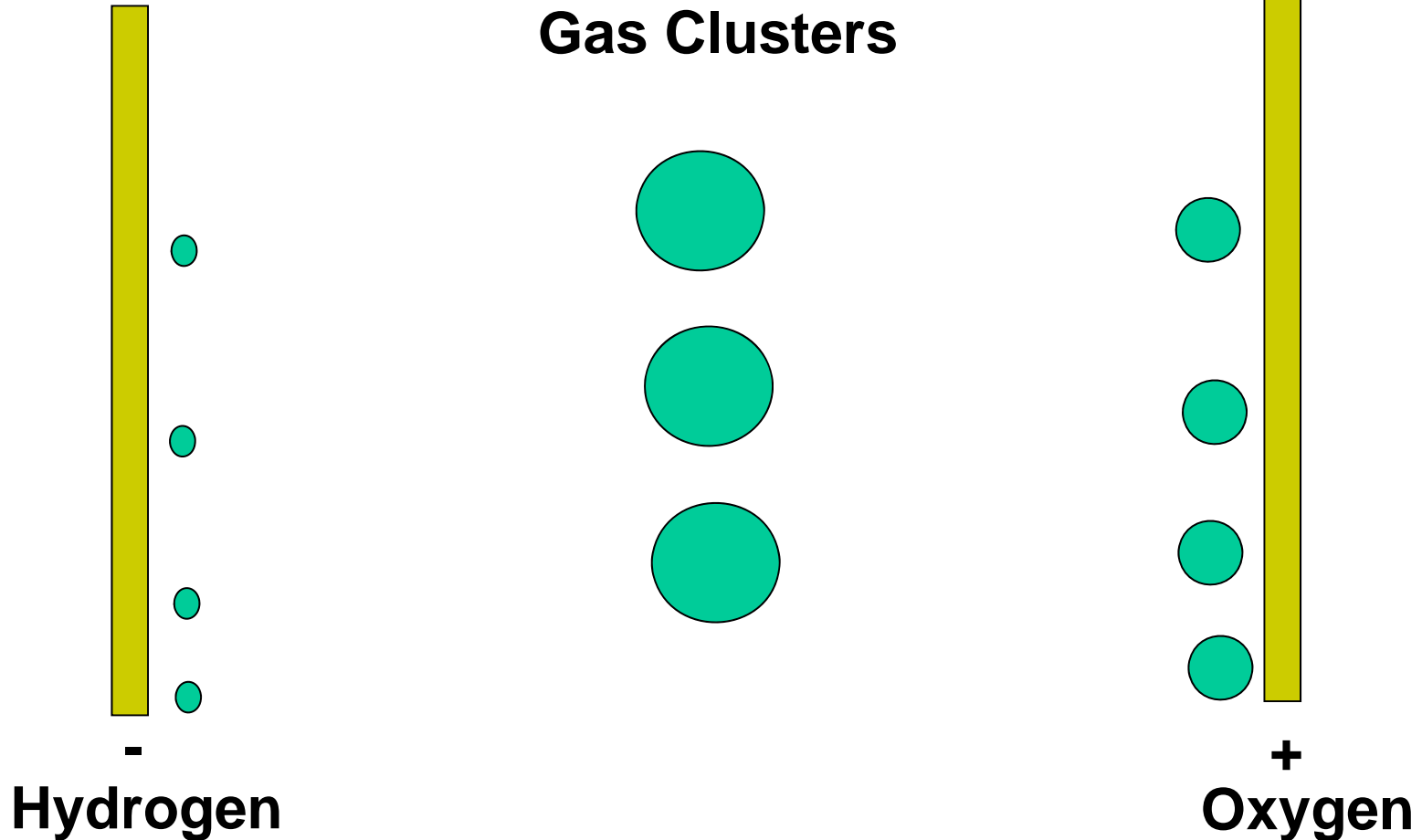



Bob Boyce: Two Colliding Jets

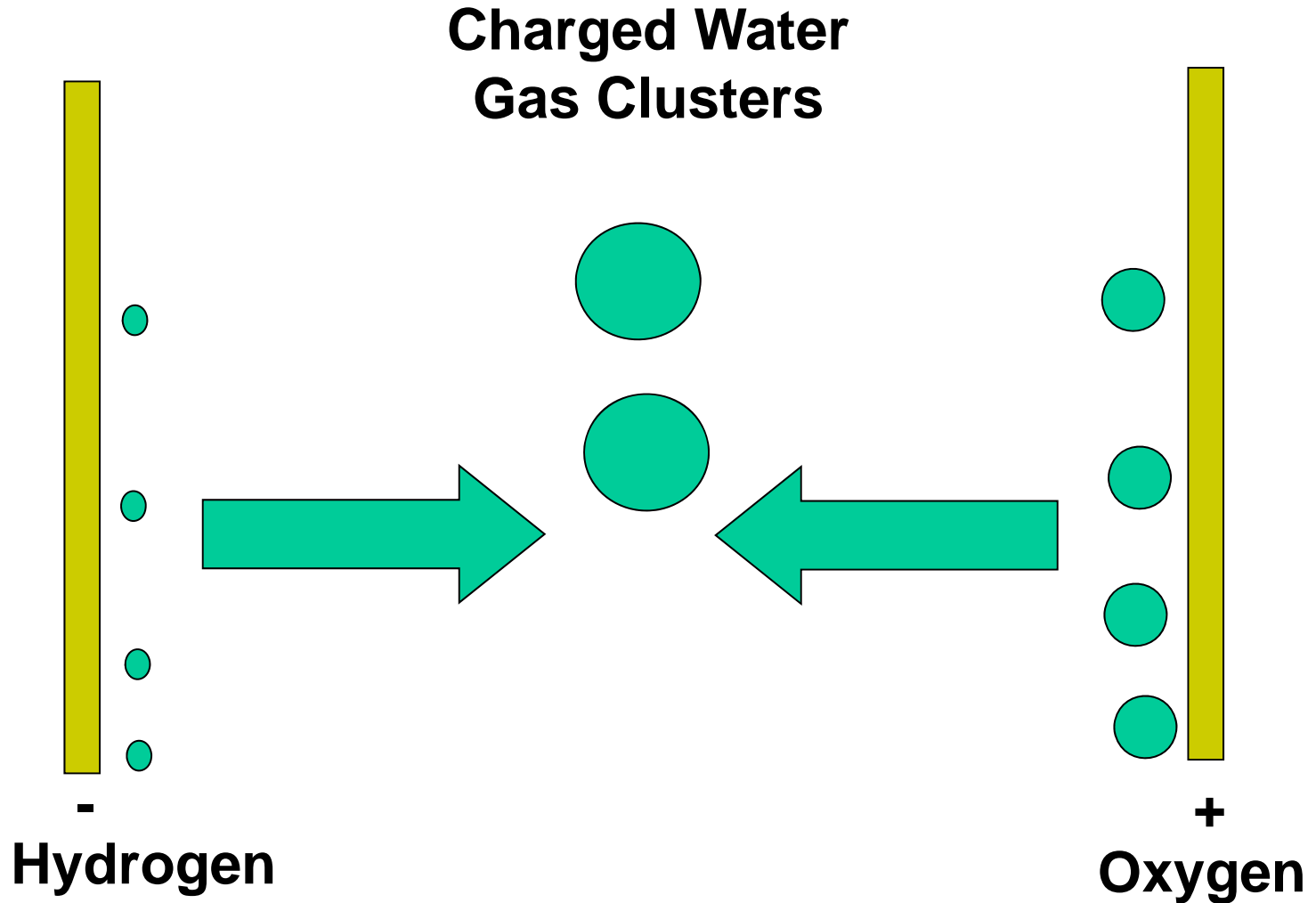



Suatt & Gourley: Harvest Middle Bubbles

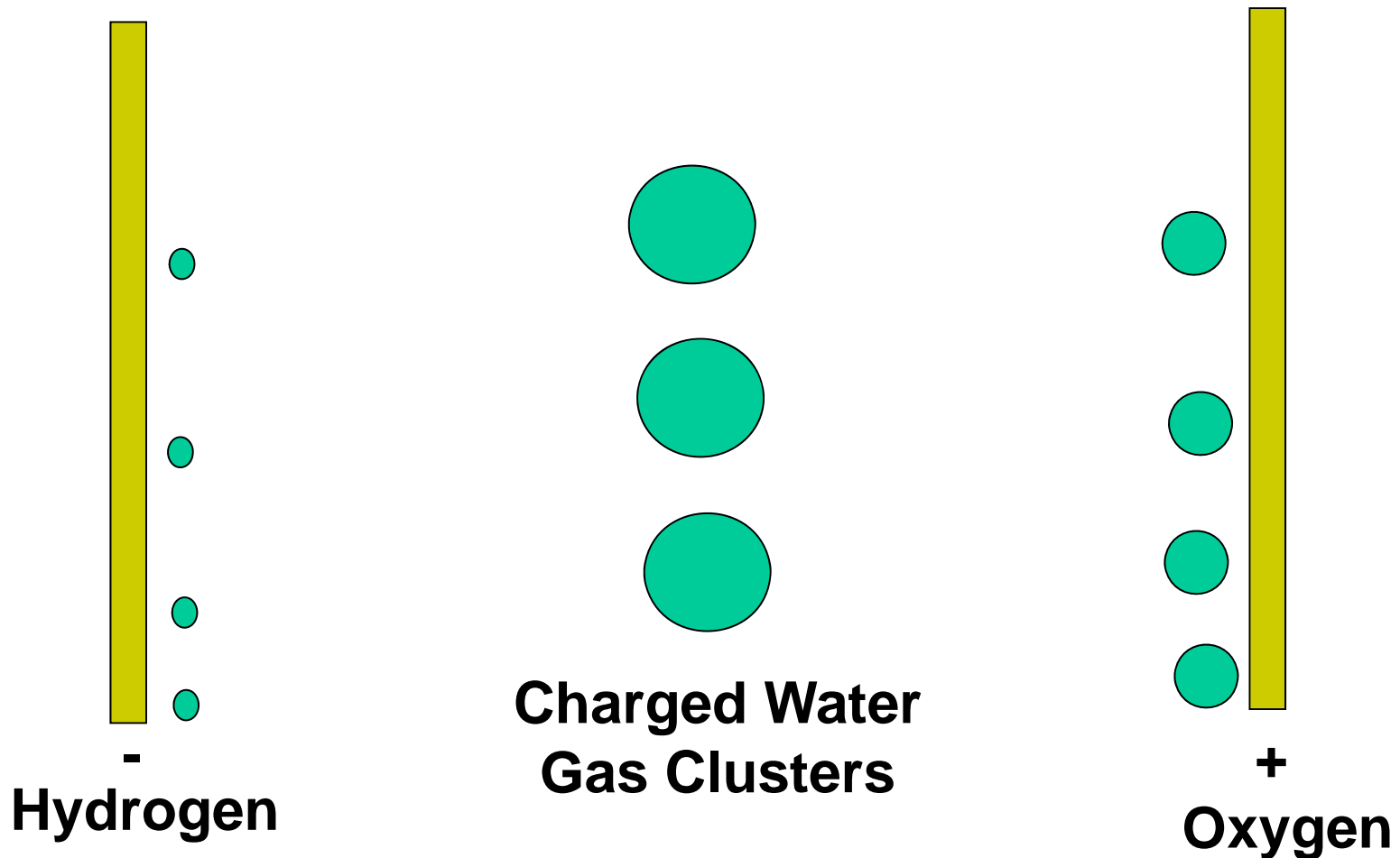



SG Gas

Extract Pure Water Gas



Ted Suartt

Rob Gourley



Ice Infused with SG Gas

Can store gas under pressure

Rhodes and Brown's gas are "dirty cocktails" with mixtures of gases including H_2 or O_2

<http://www.wateriontechnologies.com>



Brown's Gas Anomalies

- Adheres to matter (electrically polarized)
- Electric shock
- Implodes instead of explodes
- Cool flame
- Sublimates tungsten
- Cuts cleanly through wood, metal, ceramics
- Claims of neutralizing radioactive waste
- Claims of element transmutation

Todd Knudston, <http://www.amasci.com/freenrg/hydroxy.html>

George Wiseman, <http://eagle-research.com>



Vernon Roth



**Produced Element Transmutation
Within His Electrolysis Cell**

http://peswiki.com/index.php/OS:Vernon_Roth's_Alchemical_Hydrogen



Mark LeClair Explains

How Water Cavitation

Creates Microscopic Craters

Carves Trenches

Transmutes Elements

Manifests Excess Energy

Sonoluminescence

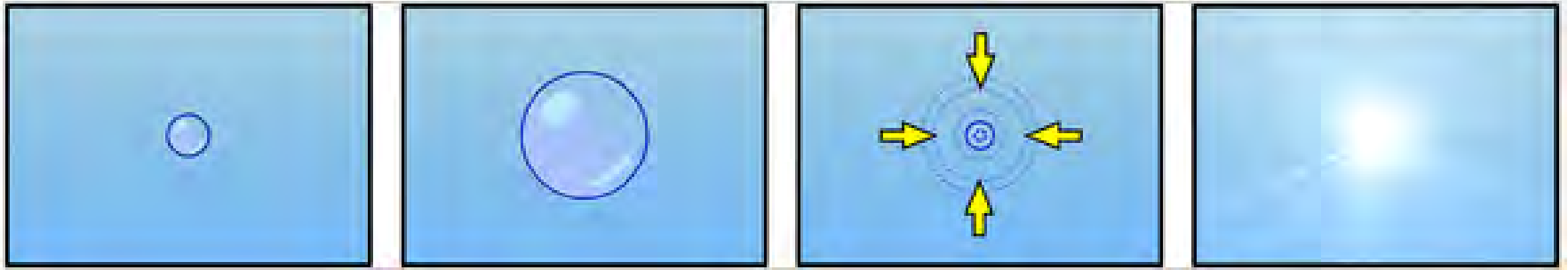

Water + Argon or Xenon

Ultrasonic Excitation

Blue Light: If Thermal $> 10,000$ K

Abrupt Scalar Compression

ZPE Coherence

<http://en.wikipedia.org/wiki/Sonoluminescence>



Torus Cavitation Bubble



Forms Near Surface

<http://nanospireinc.com/>



Collapsing Cavitation Bubble



Launches Reentrant Jet

<http://nanospireinc.com/>



Sonofusion

Roger Stringham



PIEZO &
BUBBLES
IN D₂O

PLASMA
INTO
JET PLASMA

TARGET
IMPLANT

e⁻ + D⁺ → D
& DD FUSION



PIEZO &
ACOUSTIC
WAVE

BUBBLE
GROWTH &
COLLAPSE

PLASMA
JET PINCH

JET PLASMA
IMPLANTED
D⁺ & e⁻

DD FUSION
HEAT PULSE

<http://sonofusionjets.com/>



Reentrant Jet Formation

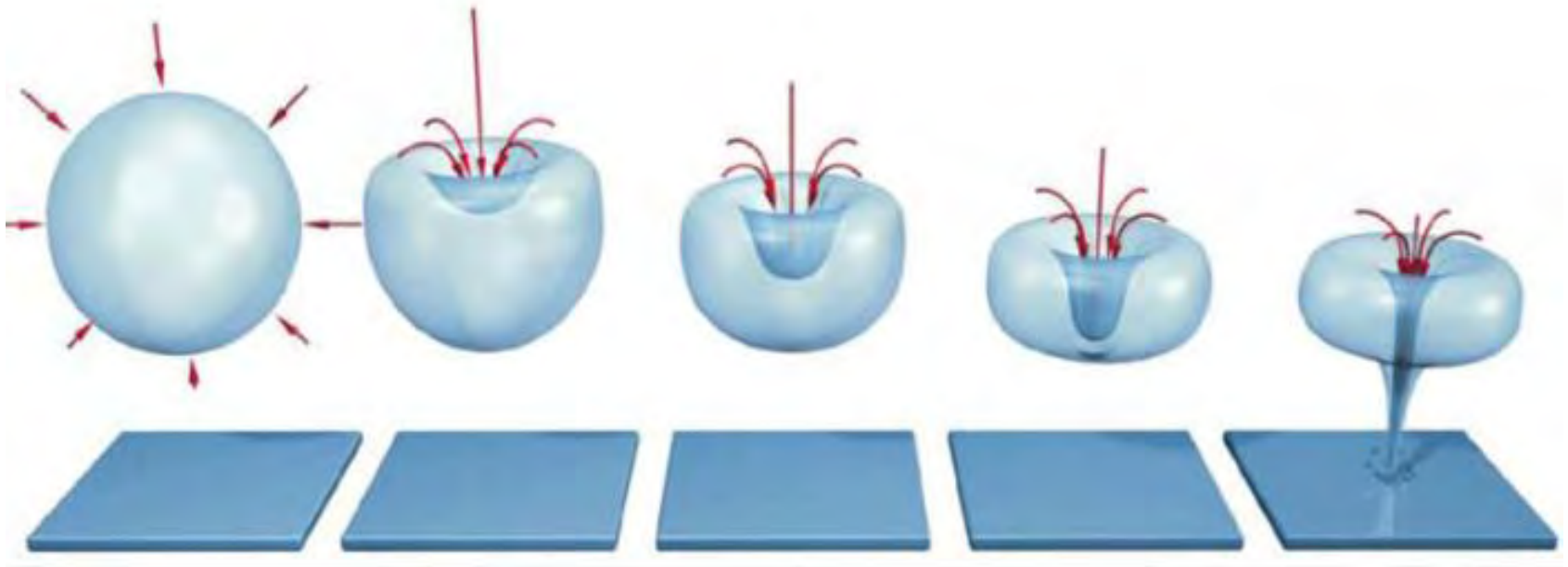

Internal Pressure: Over 300000 psi

New Solid State: Macro-ionic Water Crystal



Reentrant Jet Water Crystal

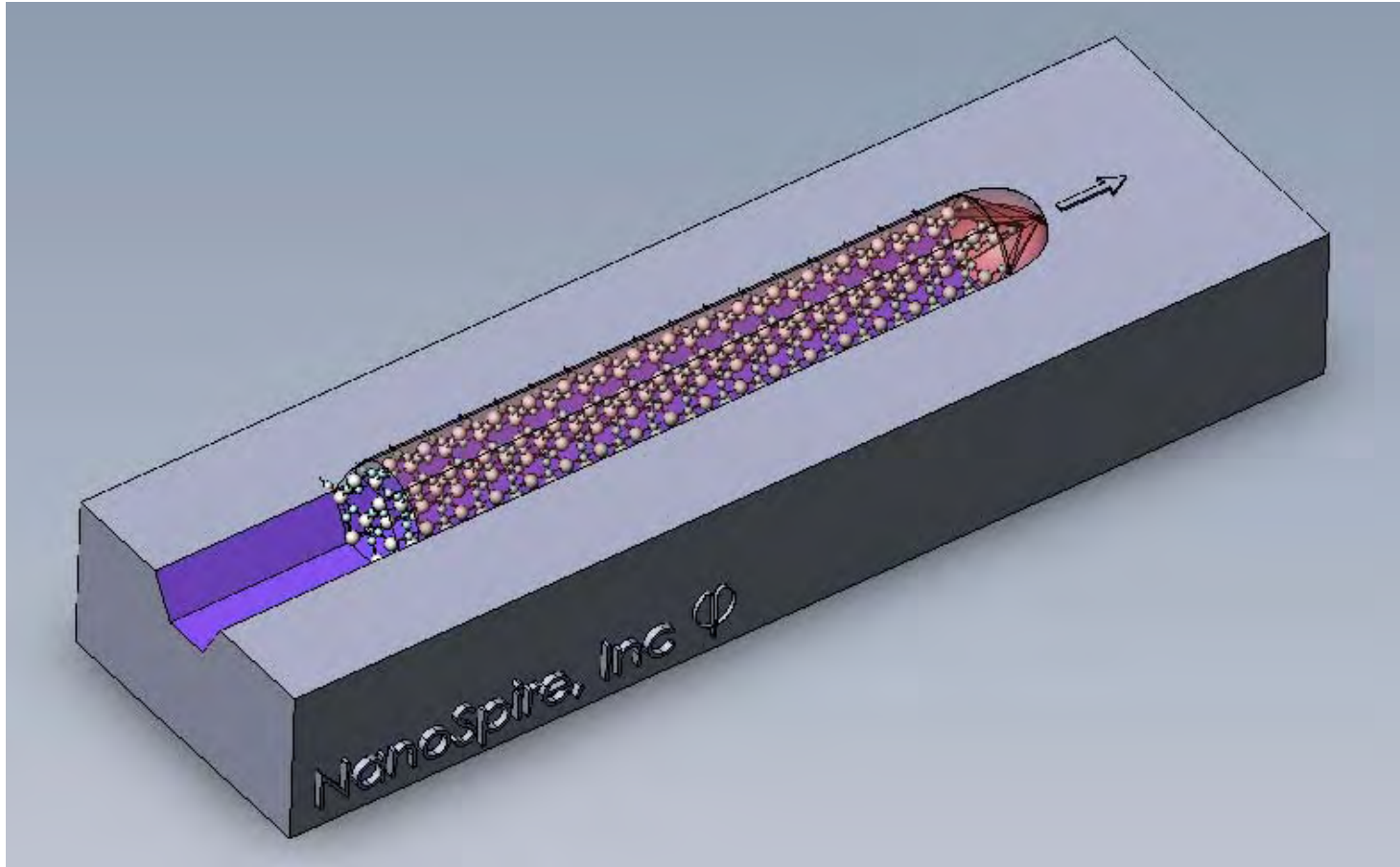

Plasma Bow Shock Wave: **ZPE Coherence**

Mark LeClair <http://nanospireinc.com/>



Mark LeClair Patents

“Method and Apparatus for the Controlled Formation of Cavitation Bubbles”

| | |
|---|----------|
| http://www.freepatentsonline.com/6932914.pdf | Aug 2005 |
| http://www.freepatentsonline.com/6960307.pdf | Nov 2005 |
| http://www.freepatentsonline.com/7297288.pdf | Nov 2007 |
| http://www.freepatentsonline.com/7517430.pdf | Apr 2009 |



Controlled Cavitation

Laser Strike

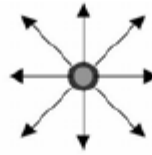

Expanding Bubble

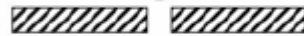
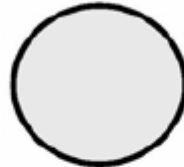

Asymmetric Collapse

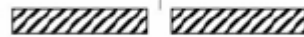
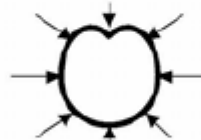

Torus Reentrant Jet

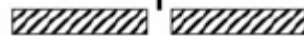

Accelerates through hole



Mark LeClair, US Patents 6,960,307 and 7,517,430

Target Cavitation

Two Laser Pulses
Out of phase

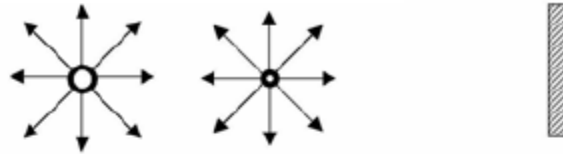

Expanding Bubbles



Asymmetric Collapse



Torus Reentrant Jets

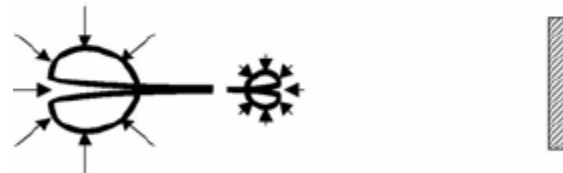

Large Jet Targets
Smaller Bubble

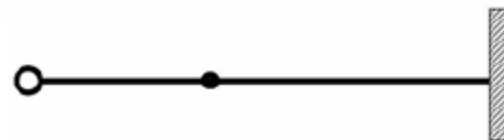

Mark LeClair, US Patents 6,932,914 and 7,297,288

LeClair Controls Reentrant Jet

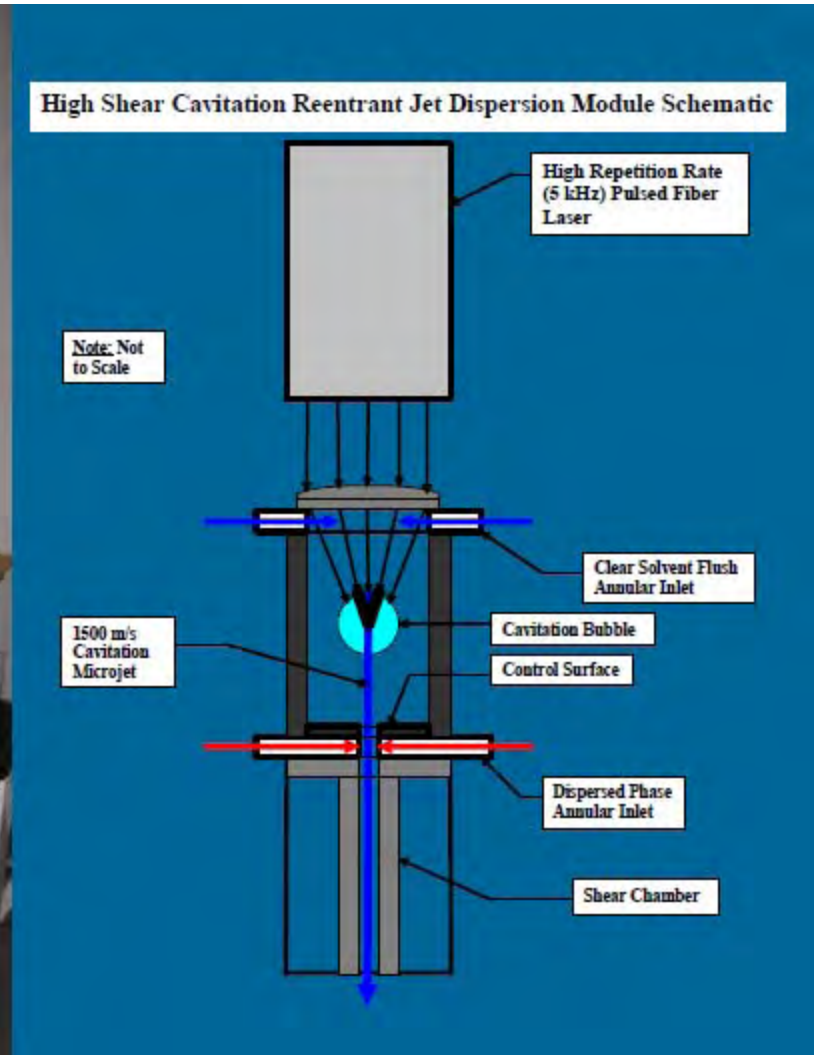

<http://nanospireinc.com/>

Pistol Shrimp



[Play](#)

<http://www.youtube.com/watch?v=eKPrGxB1Kzc>

Propeller Cavitation



<http://www.ionizationx.com/index.php/topic,1239.5.html>

Cavitation Erosion

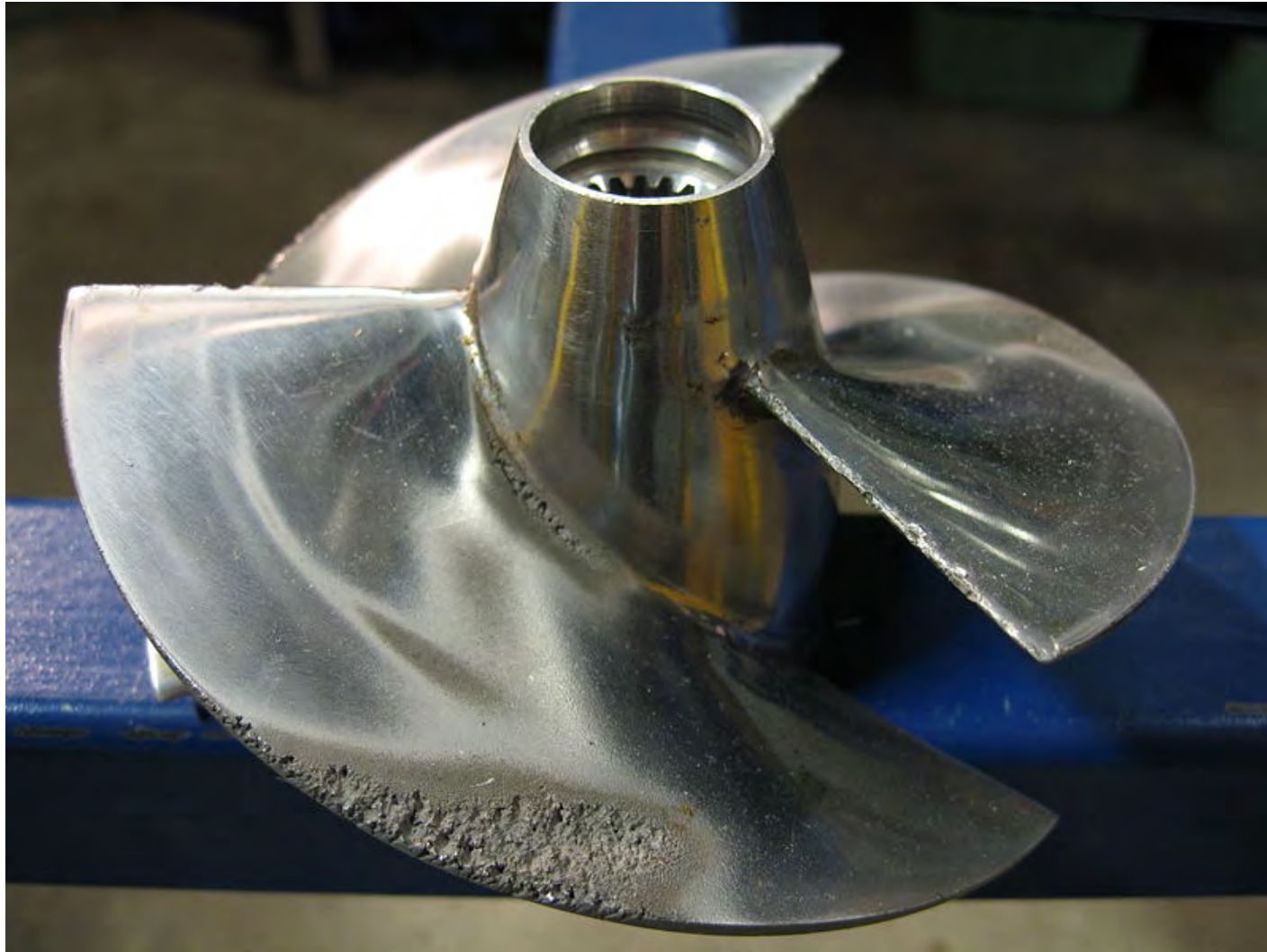

<http://www.ionizationx.com/index.php/topic,1239.5.html>



Reentrant Jet Water Crystal

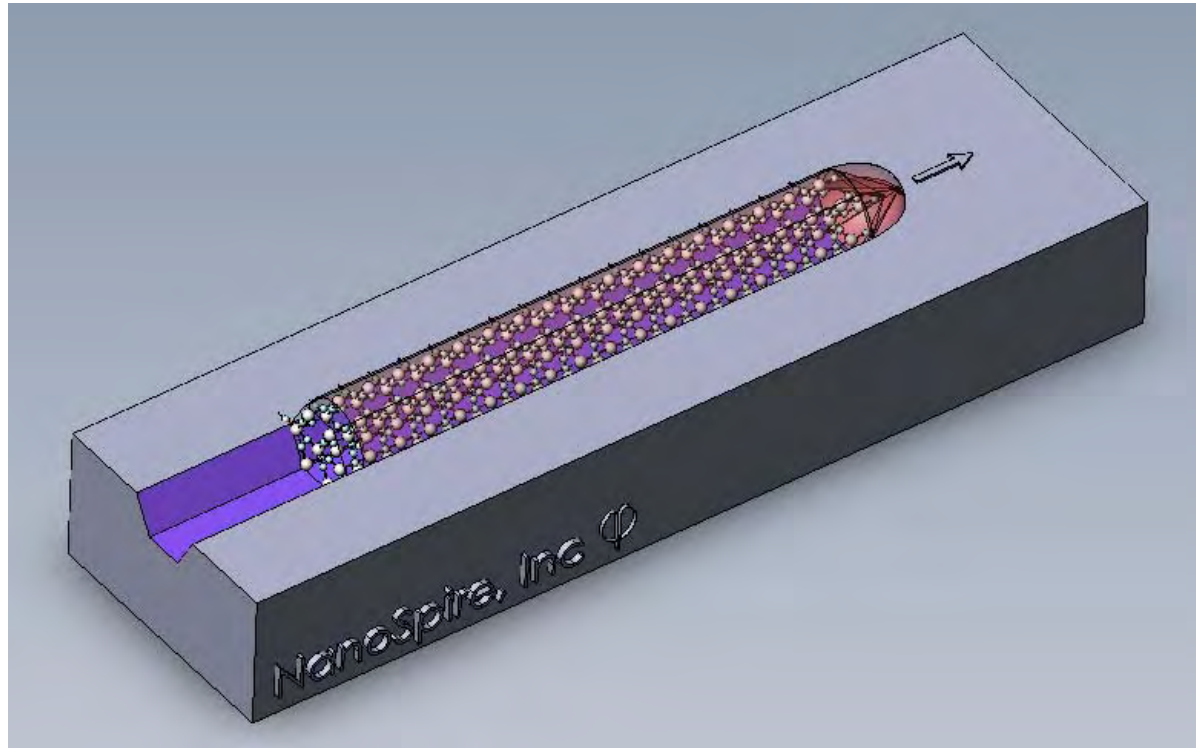

Hexagonal Form

Linear Axis

Mark LeClair <http://nanospireinc.com/>



Water Crystal Structure

**Down Axis:
Covalent Bonds**

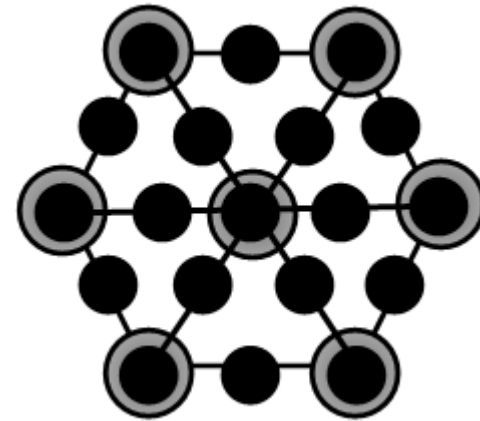
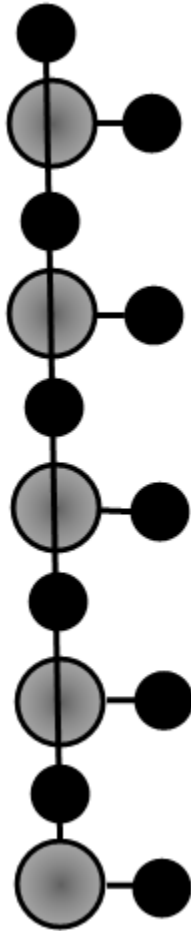

**Across Plane:
Hydrogen Bonds**



Water Crystal Structure 3D

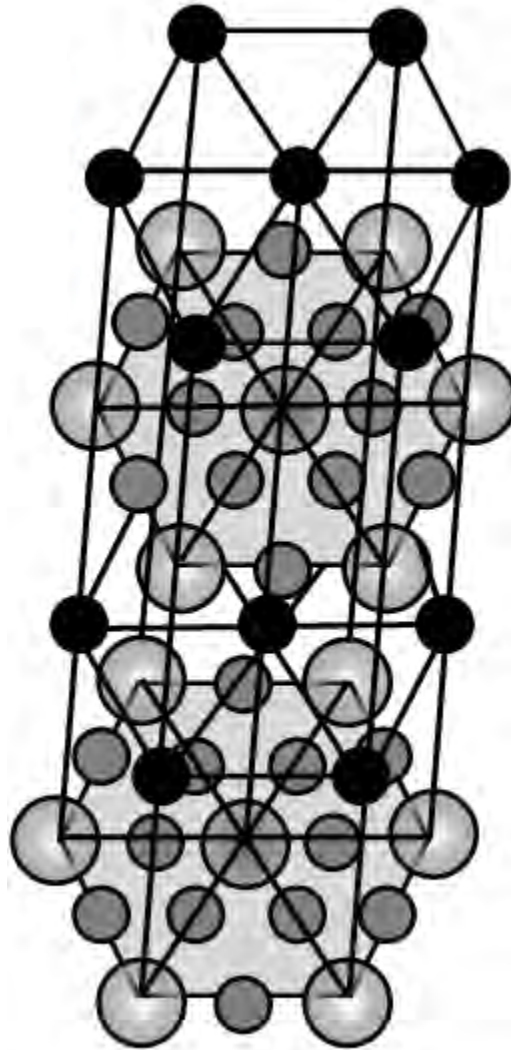

Mark LeClair <http://nanospireinc.com/>



Macroionic Water Crystal Imprint

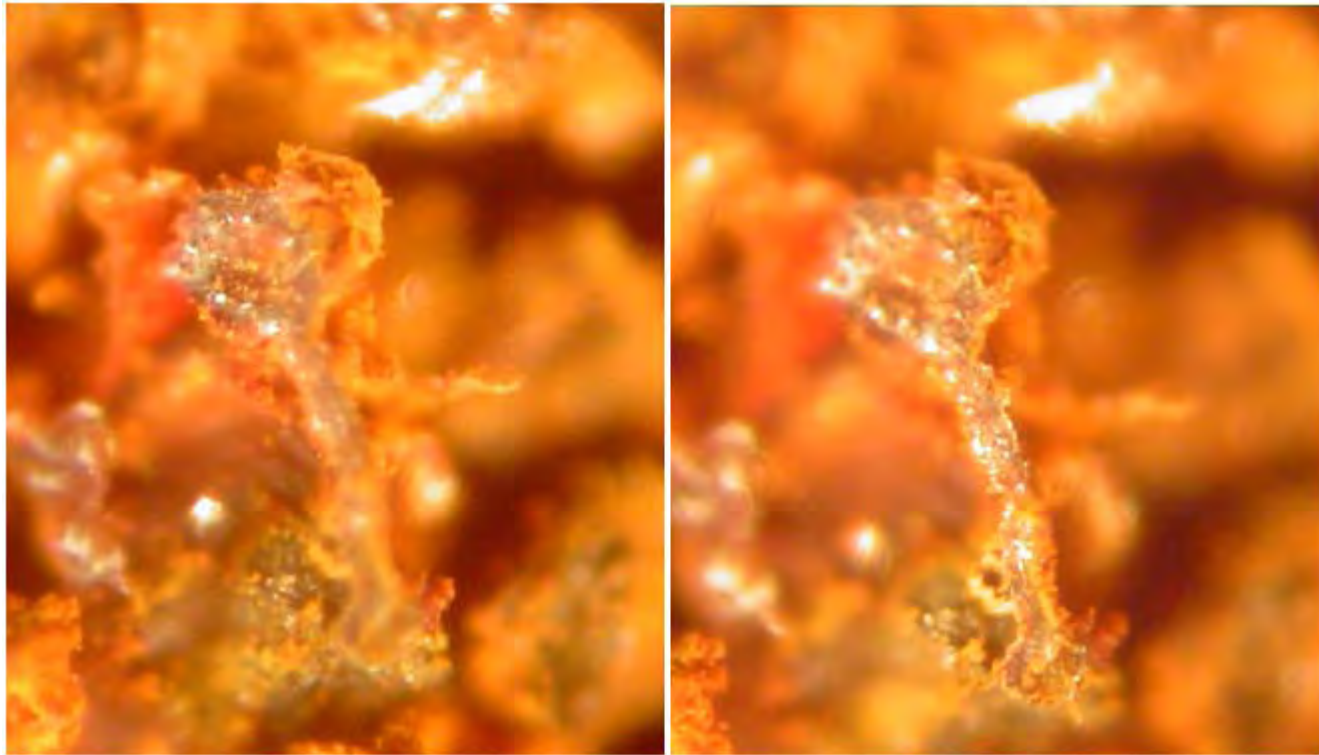

← 3 mm →

Mark LeClair <http://nanospireinc.com/>



Reentrant Jet Characteristics

- Velocity: 1500 m/s Up to Mach 4
- Pressure: > 100,000 psi
- Water Crystal
 - Axis: Linear HOHOHOHO...
 - Shape: Trigonal, Hexagonal
 - Head: Positively Charged
 - Tail: Negatively Charged
- Head: Plasma Bow Shock
 - Creates Craters
 - Carves Trenches
 - **Self-Accelerates**

**Shoulders' EVO
Does Likewise**

LeClair Effect

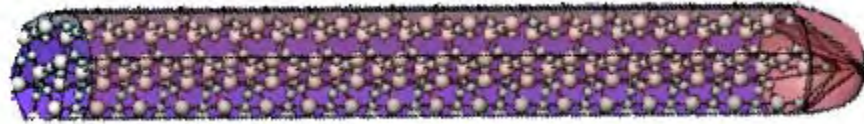

Bow Shock – ZPE Coherence

Like Shoulder's EVO

Manifests Self-Acceleration

Causes Nuclear Reactions



Water Crystal Carves Trenches

Aluminum Oxide

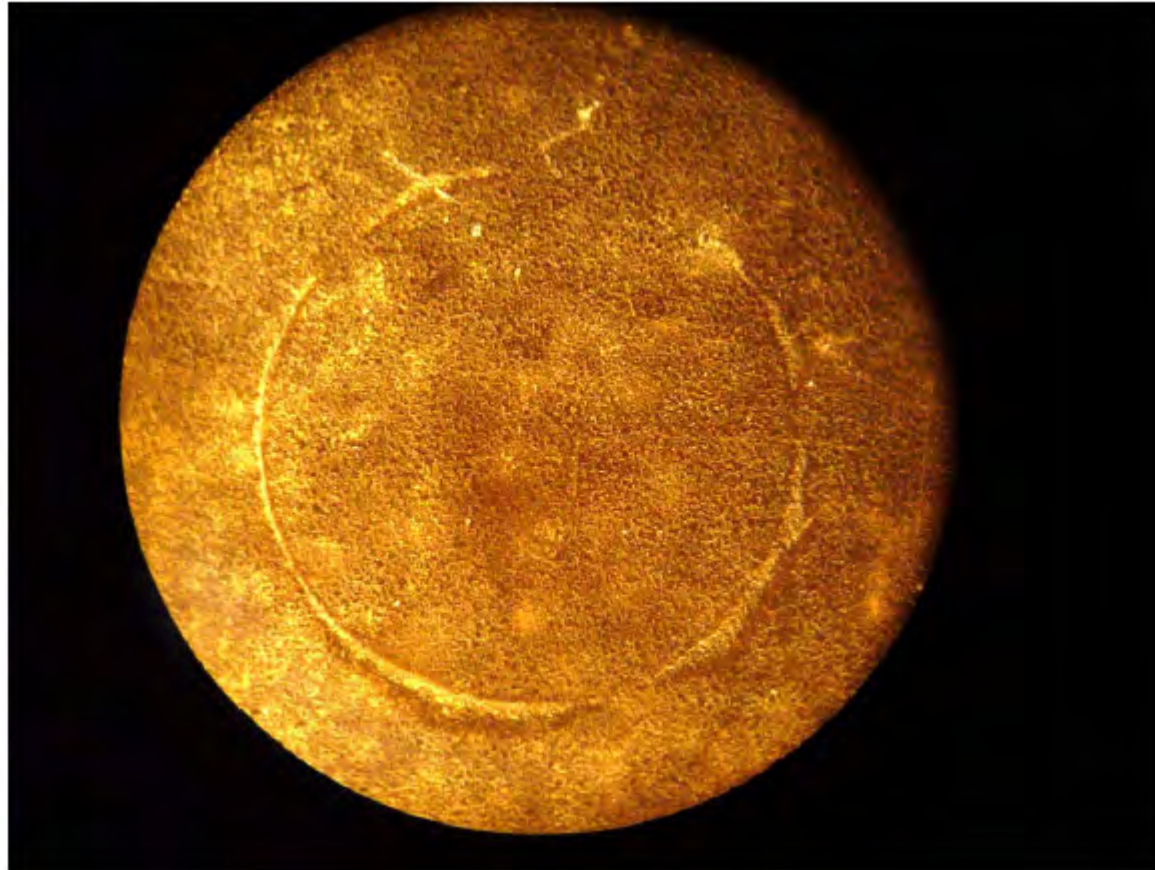

← 2 mm →

Mark LeClair <http://nanospireinc.com/>



Mark LeClair's

Transmutation Experiment



Assembly Components

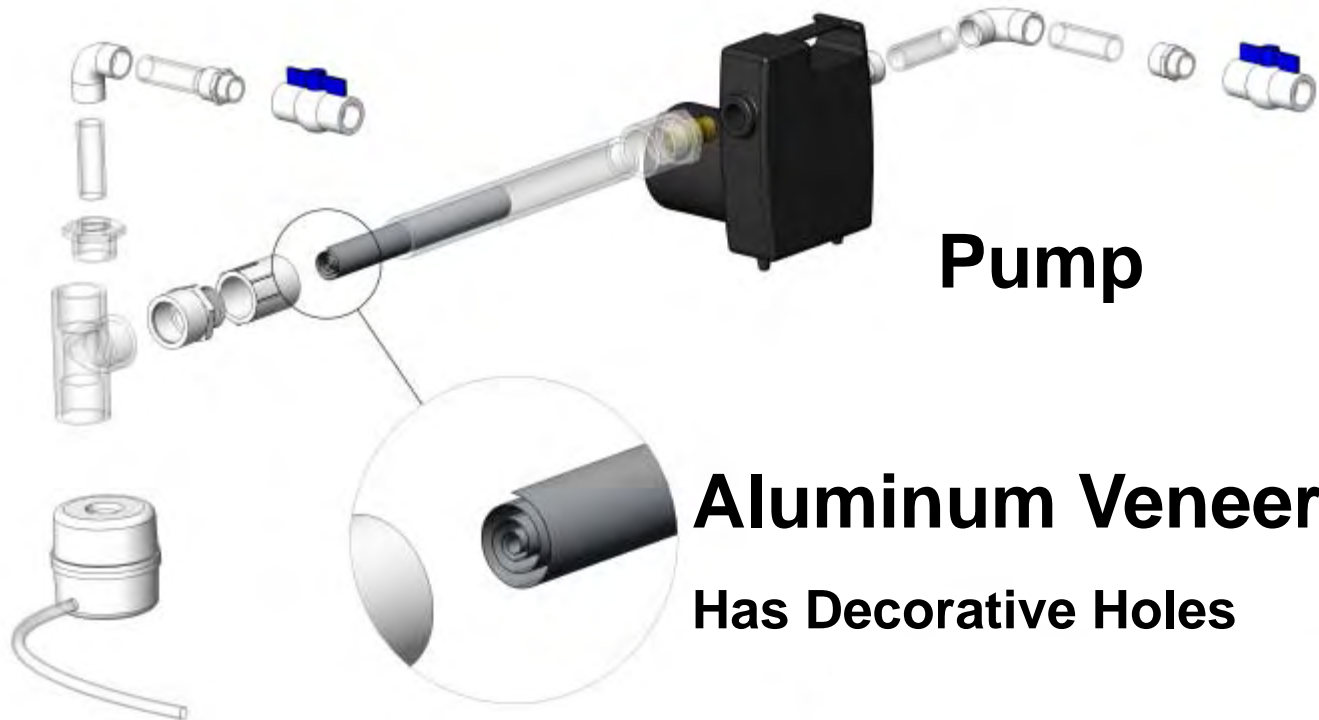

Pump

Aluminum Veneer

Has Decorative Holes

Mark LeClair <http://nanospireinc.com/>



Assembled Apparatus

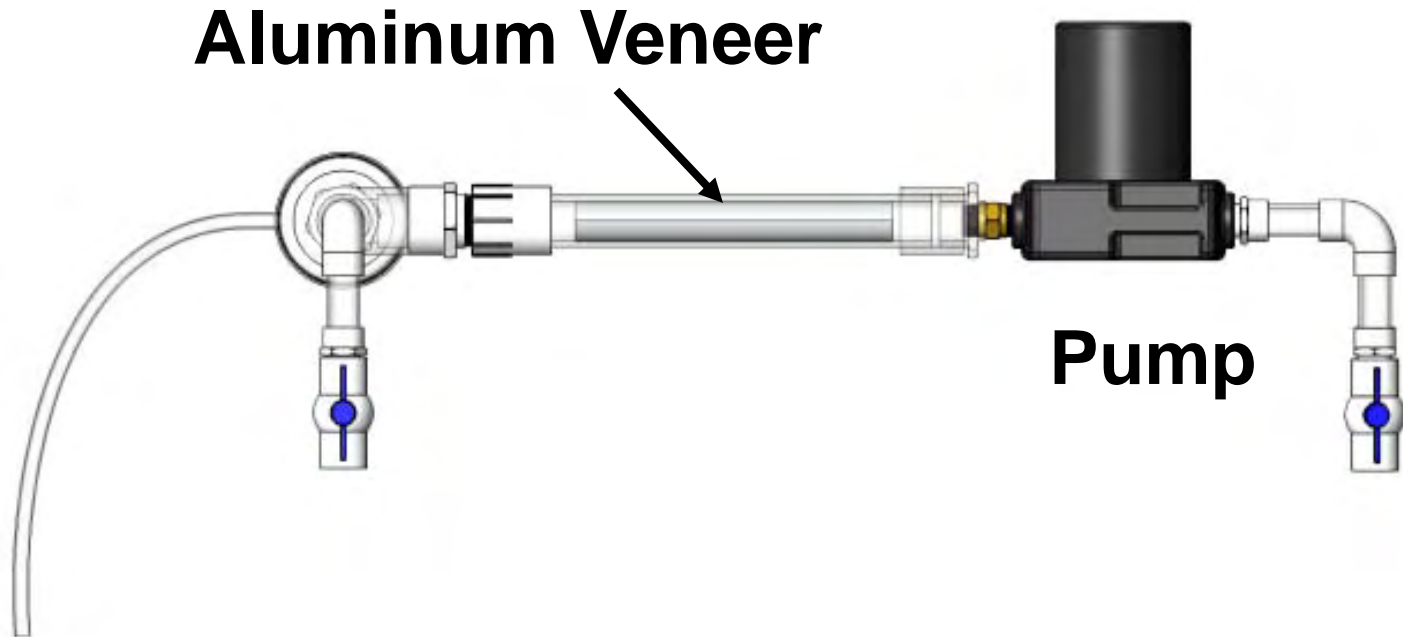

Mark LeClair <http://nanospireinc.com/>

Experimental Setup

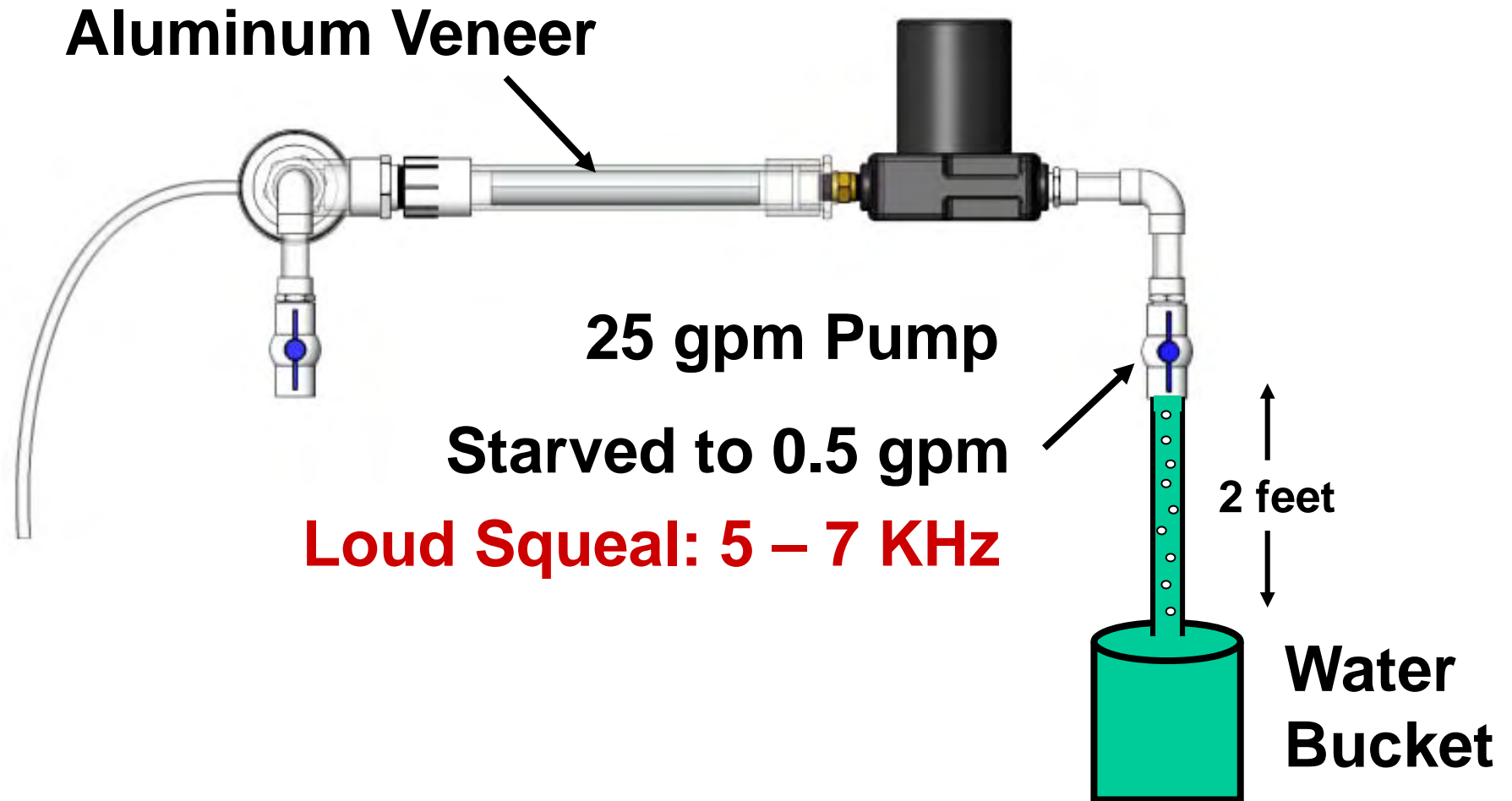

Mark LeClair <http://nanospireinc.com/>

Aluminum Veneer

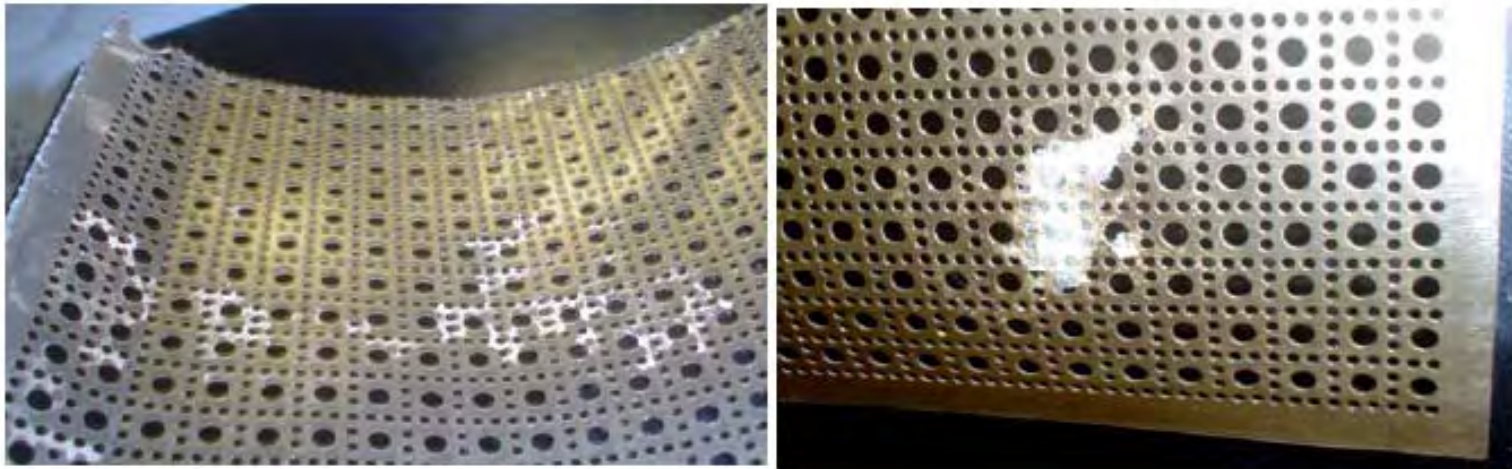

Transmuted Elements on Surface

Carbon in Diamond Form (white blotch)

Mark LeClair <http://nanospireinc.com/>

Nucleosynthesis

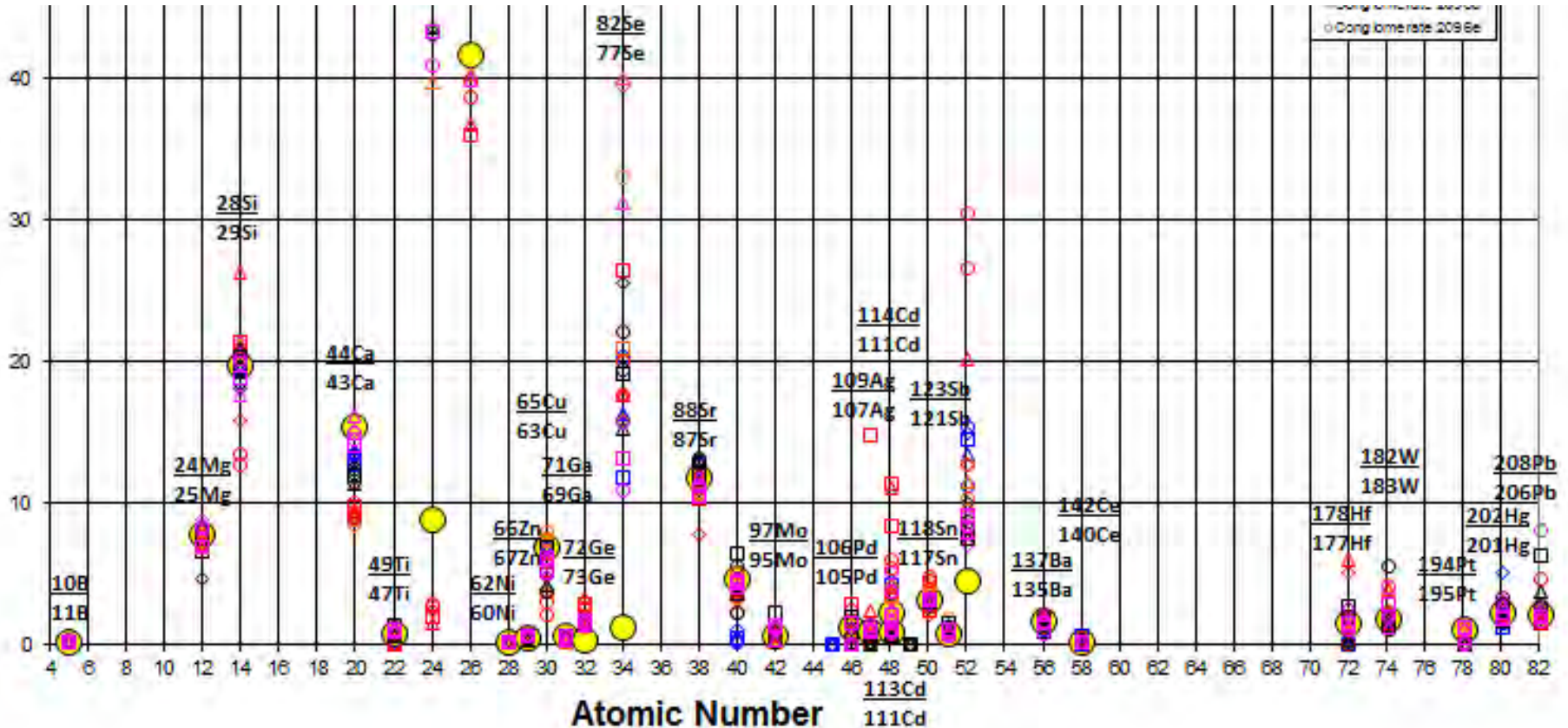

Rare Isotopes

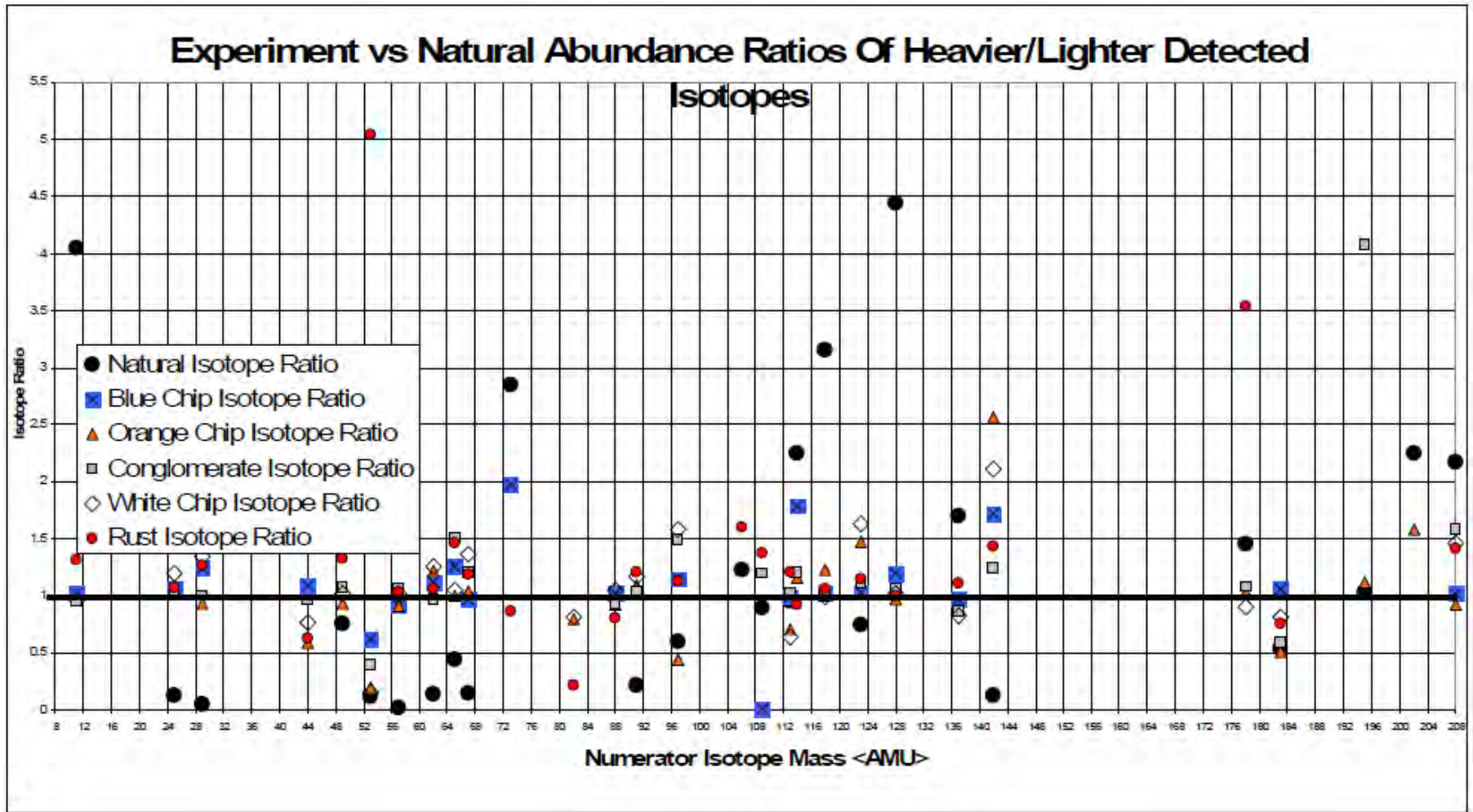

Multiples of Helium Nucleus



EVO & Plasmoid Strikes

Also Exhibit Transmuted Isotopes
across the Periodic Table

Akin to Nucleosynthesis in a
Supernova



Low Voltage Transmutation

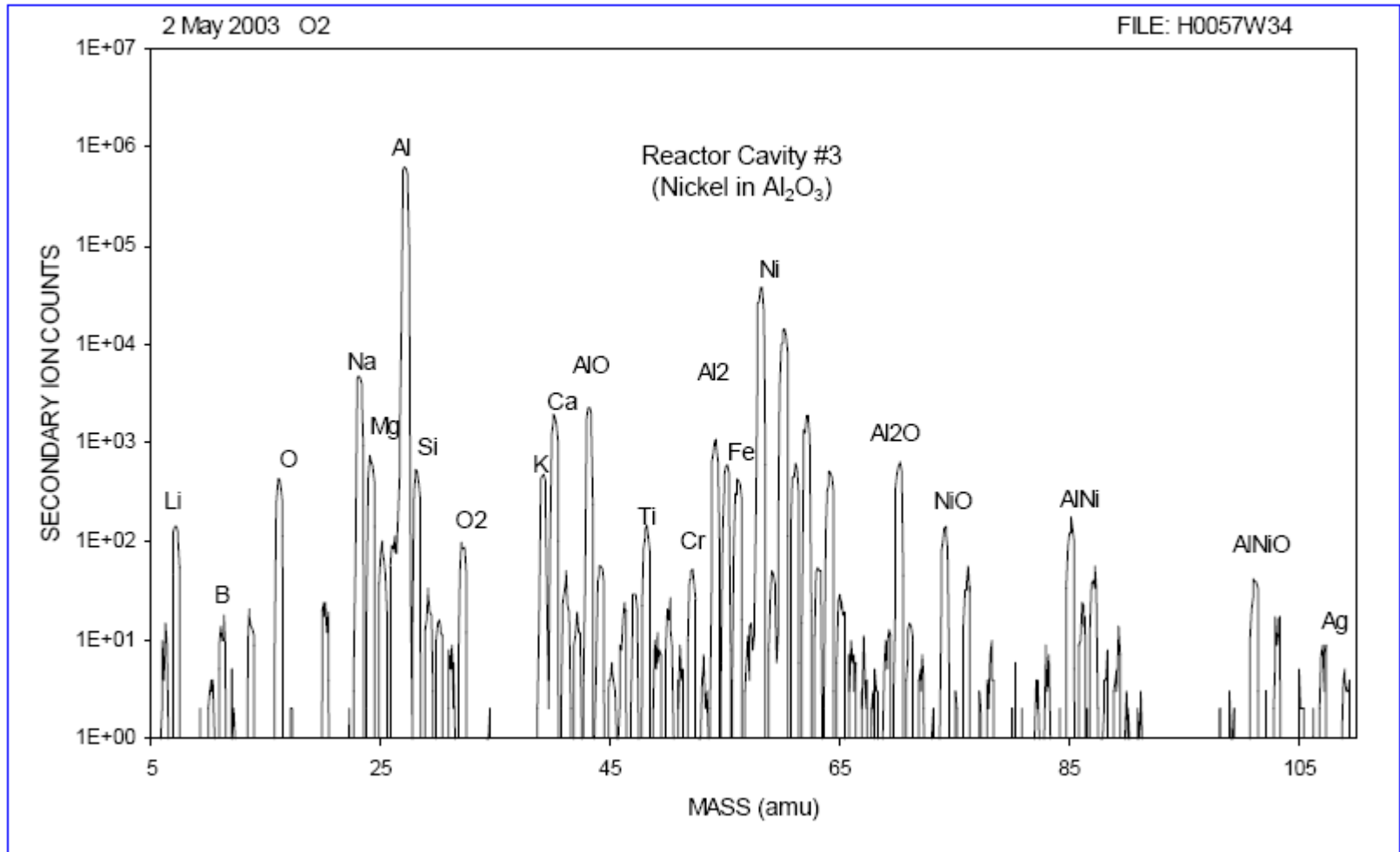

Ken Shoulders

<http://www.svn.net/krcsfs/ICCF-10+Low+Voltage+Nuclear+Transmutation.pdf>

Nucleosynthesis

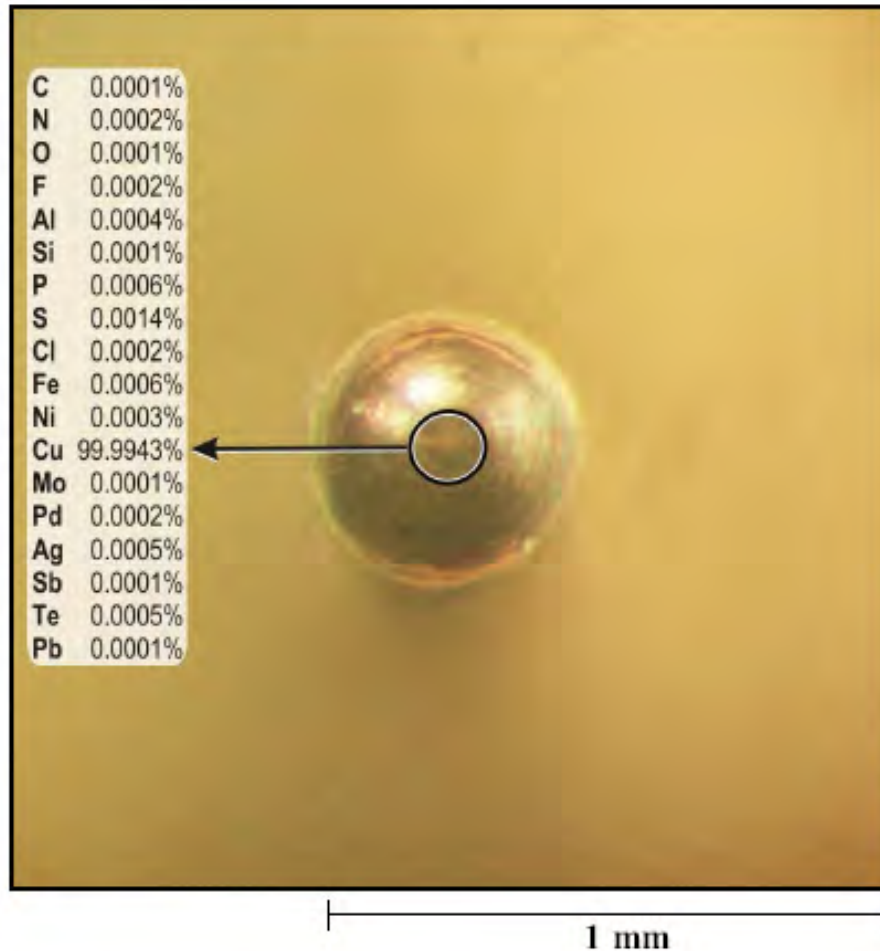

Adamenko, et al.

http://www.proton21.com.ua/articles/Booklet_en.pdf

Nucleosynthesis

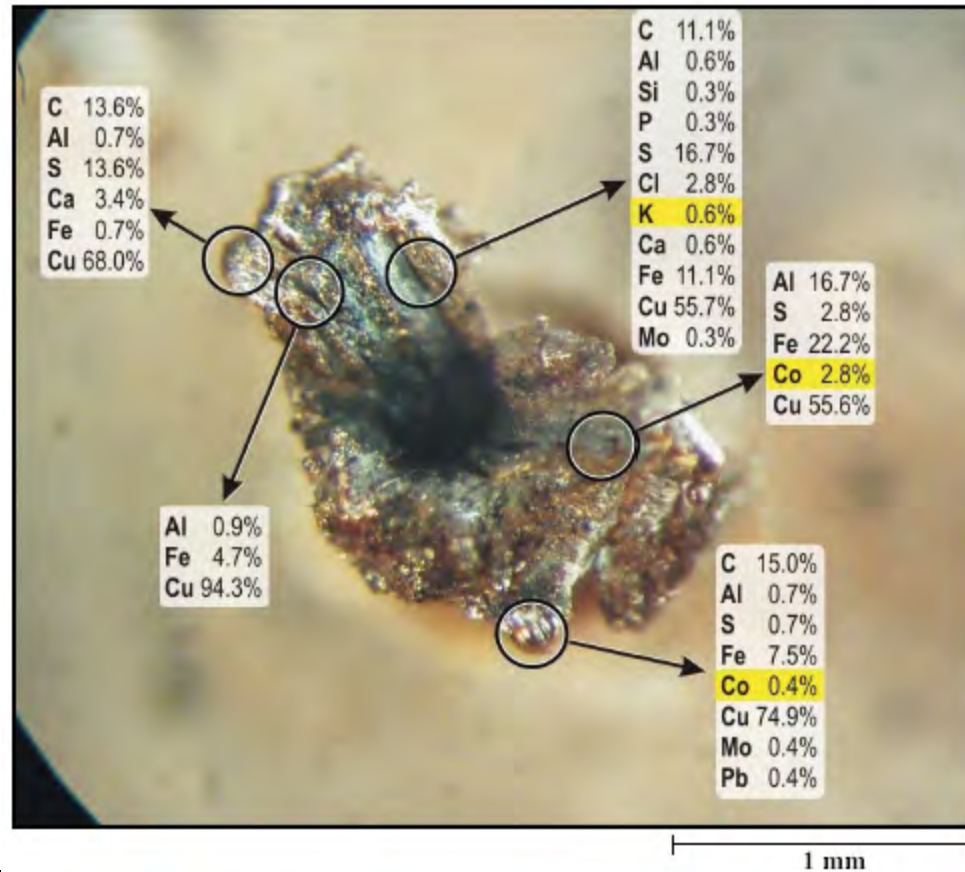

Adamenko, et al.

http://www.proton21.com.ua/articles/Booklet_en.pdf

Annual Conferences in Russia



The 16th Russian Conference on Cold Nuclear Transmutation and Ball-Lightning (RCCNT&BL-16)

Dagomys, Sochi, Russia

June 1 - June 8, 2009

RCCNT&BL-16 INVITATION [Download](#)

[PROGRAM COMMITTEE of RCCNT&BL-16](#)

[ORGANIZING COMMITTEE of RCCNT&BL-16](#)

[RESOLUTION of RCCNT&BL-16](#)

[PROGRAM & ABSTRACTS of RCCNT&BL-16](#)

<http://www.iscmns.org/rccnt16/>



Action Item: Physics Departments

- Repeat LeClair's Transmutation Experiment
- Measure New Isotopes
- Ask Colleagues to Replicate



How Does Cavitation Relate to Brown's Gas?

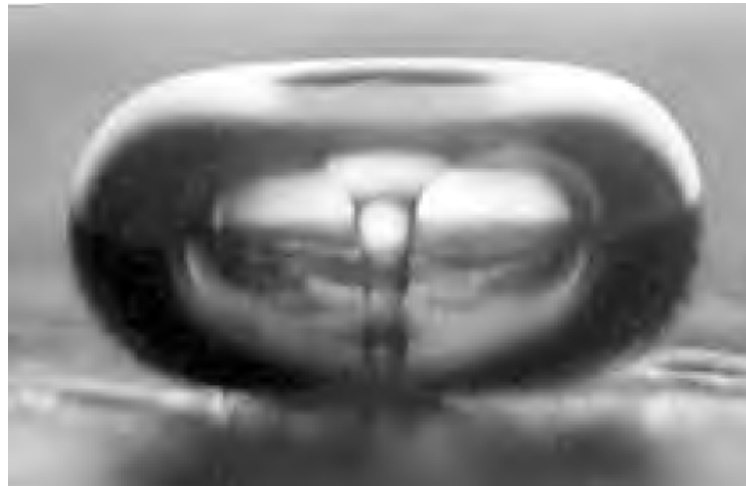

**Collapsing Bubble Launches
Reentrant Jet**



Reentrant Jet Water Crystal



Axis Linear Chains

...HOHOHOHOHOHO...

Chris Eckman

Plasma Orbital Expansion of the Electrons in Water

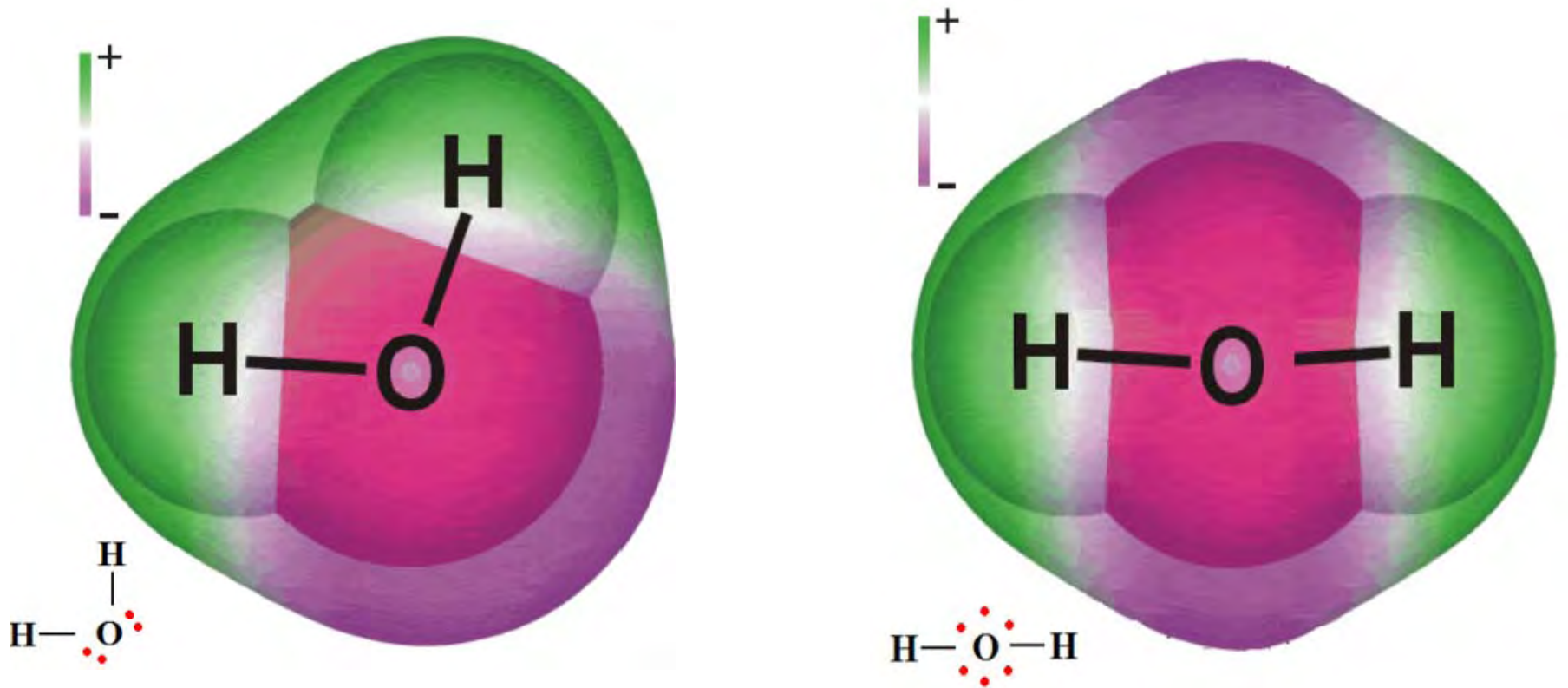

Linear Water Isomer with Extra Electrons

Proc. NPA, vol. 6, no. 2 (2010)

Chris Eckman

Plasma Orbital Expansion of the Electrons in Water

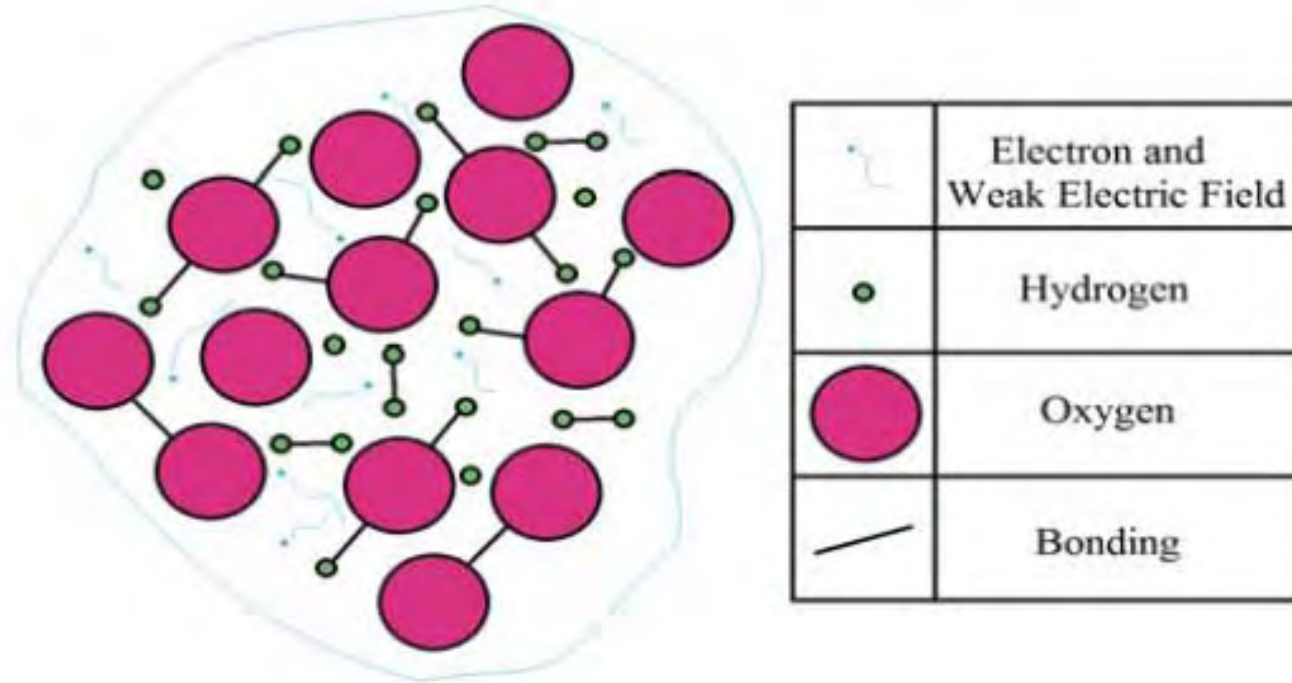

Linear Water Stable in Rydberg Cluster

Rydberg Matter

Meta-stable Cold Plasma

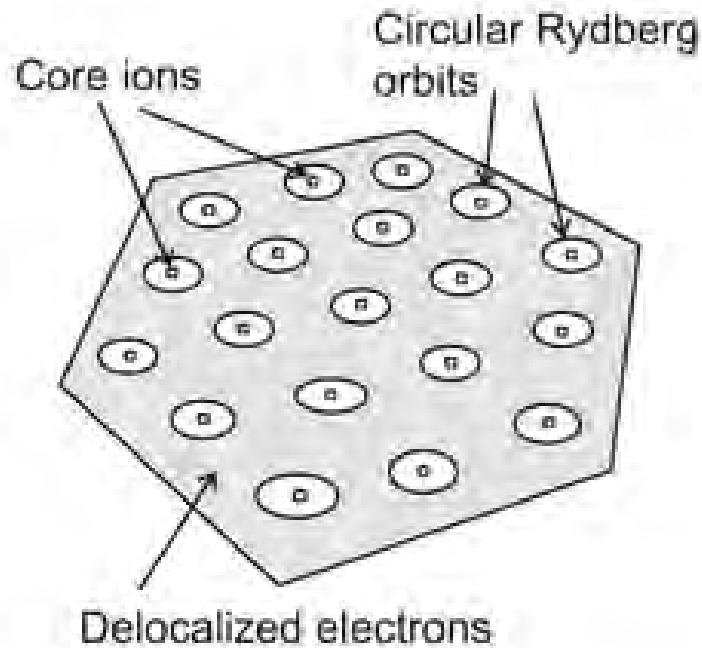

D orbital electrons - high energy state

http://en.wikipedia.org/wiki/Rydberg_matter



Linear Chains

Along Axis of Water Crystal

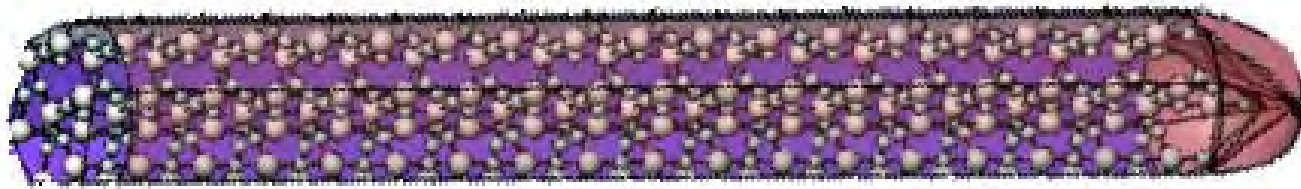
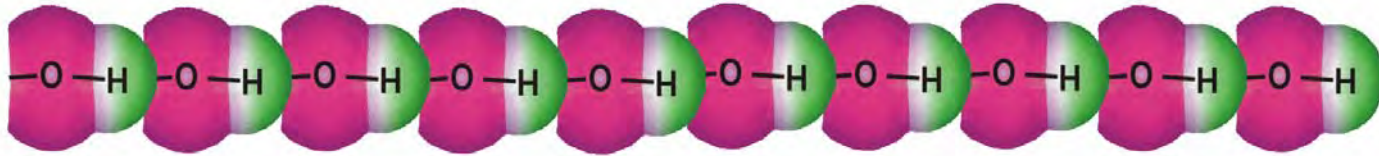

How can its energy be captured?



Long Water Crystal Can Close Into Loop

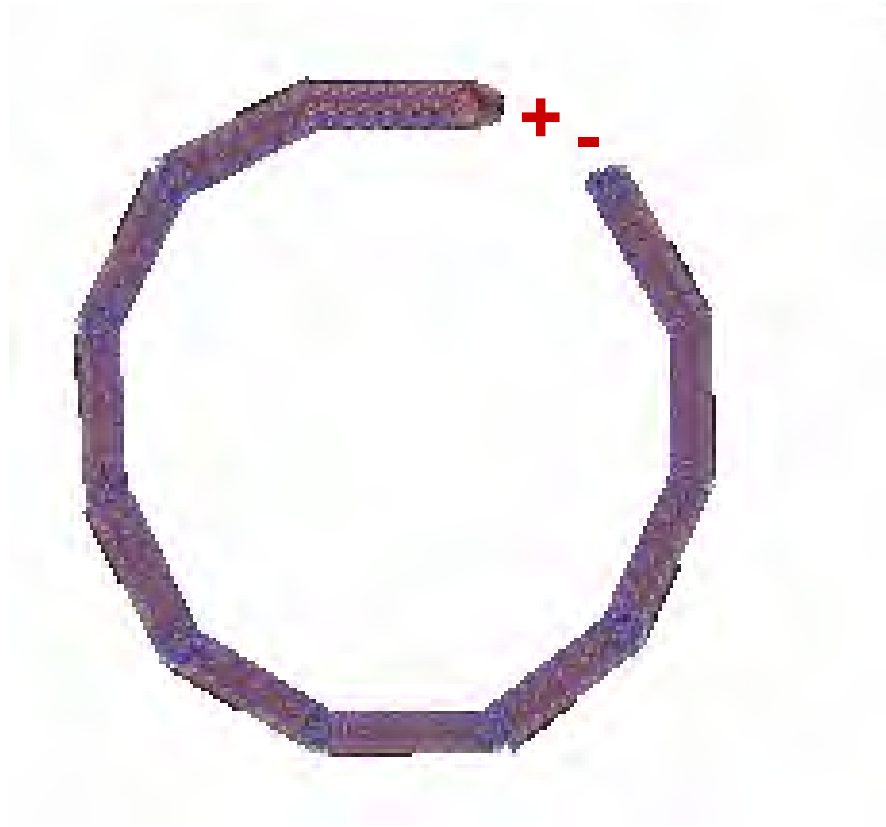

Positive Head Attaches to Negative Tail



To Form Water Crystal Ring

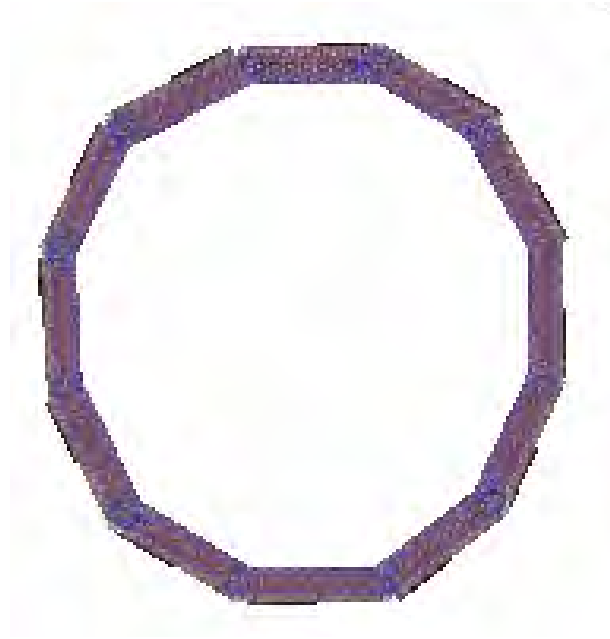

Large Ring is Unstable



Fractal Decay into Smaller Rings

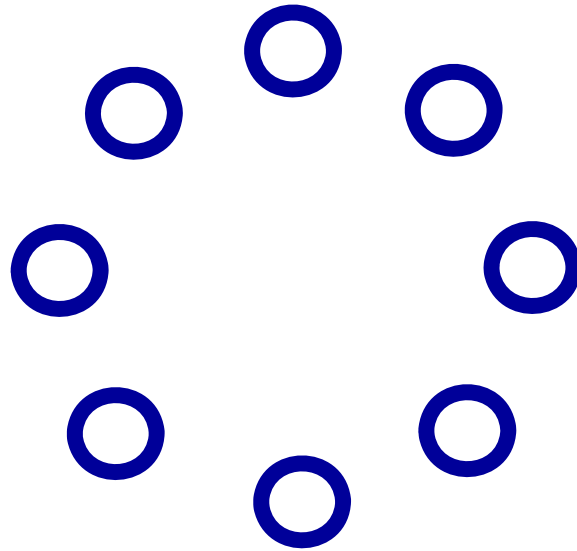

Like Decomposing Vortex Ring



Small Ring: Seed of Water Cluster Gas

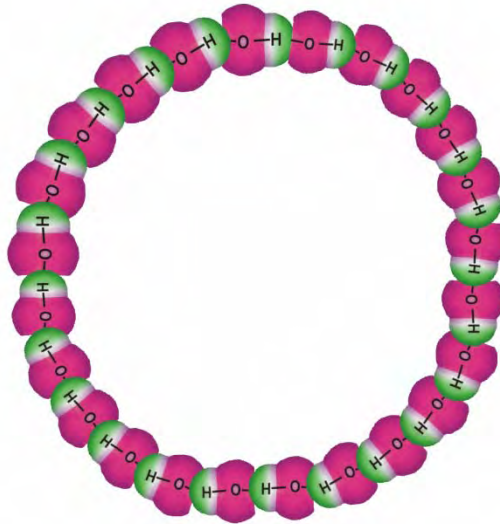

Stable Under 0.5 Microns

Mark LeClair <http://nanospireinc.com/>



Water Crystal Collisions

**Produce Small Ring,
Water Cluster Seeds**

Two Approaching Water Crystal Jets



Two Approaching Water Crystal Jets



Two Approaching Water Crystal Jets





Two Approaching Water Crystal Jets

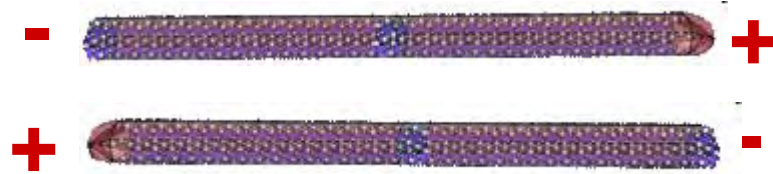

Attract Head to Tail



Shear Collision

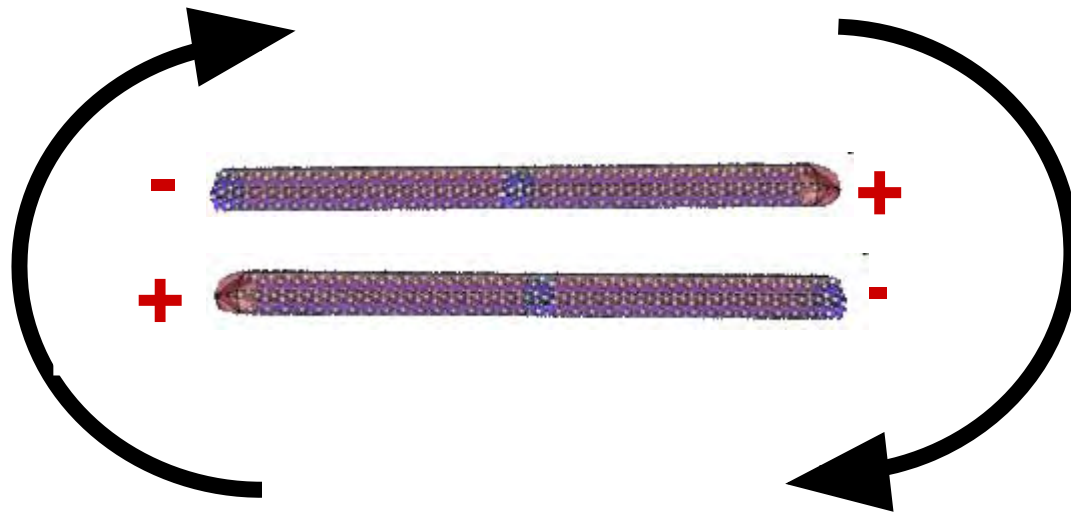

Spirals Into Vortex



Shear Collision Debris

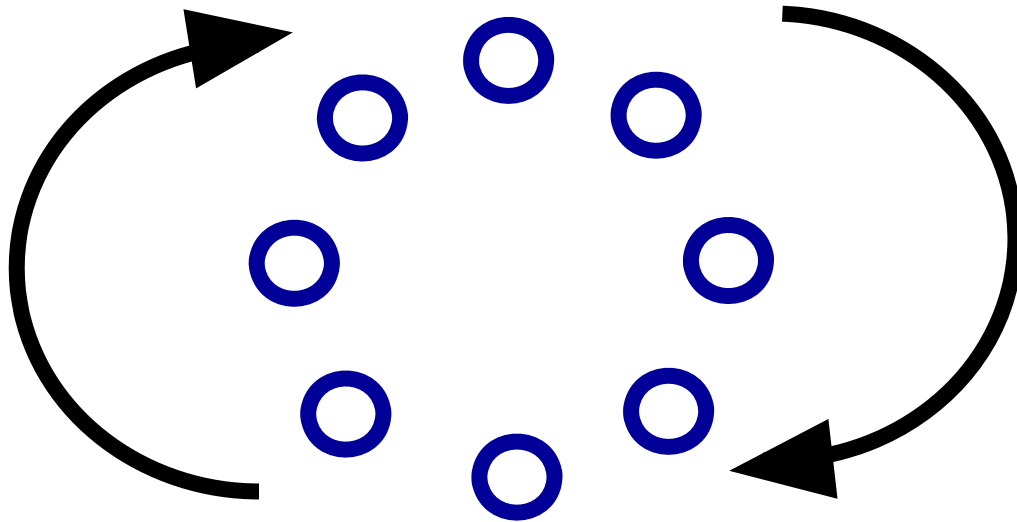

Small Water Crystal Rings

Small Water Crystal Ring

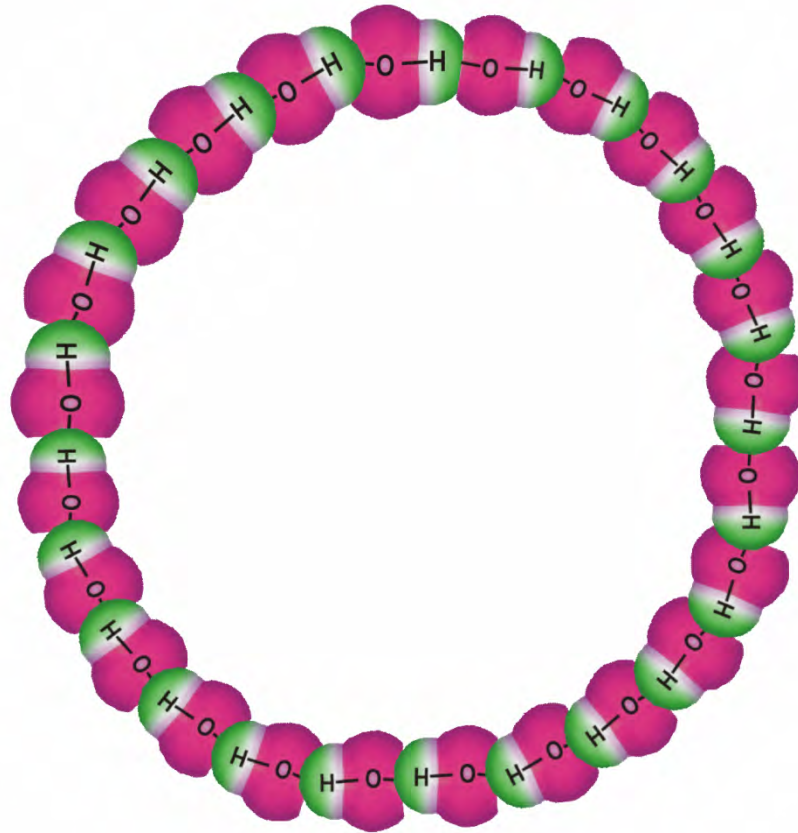

Electrons held in d orbitals – Rydberg Matter



Small Water Crystal Ring

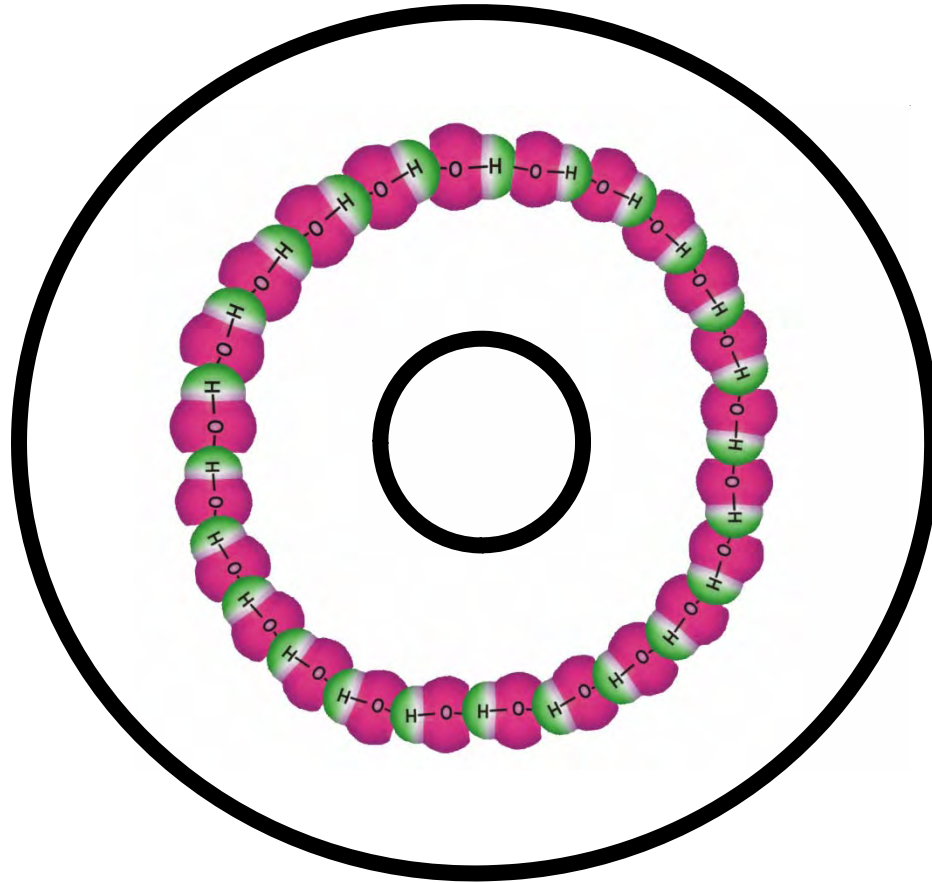

Electrons in Outer d Orbitals

Meta-Stable Torus Form



Breaking the Ring

Re-launches Water Crystal

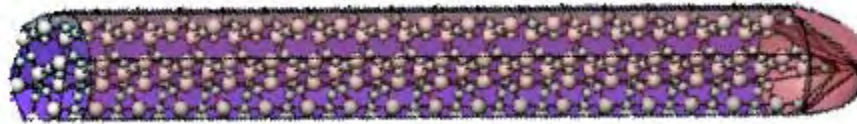

**Coherent ZPE Bow Shock Causes
LeClair Effect, Nuclear Reactions**

<http://nanospireinc.com/>



When Ignited Ring Converts to EVO

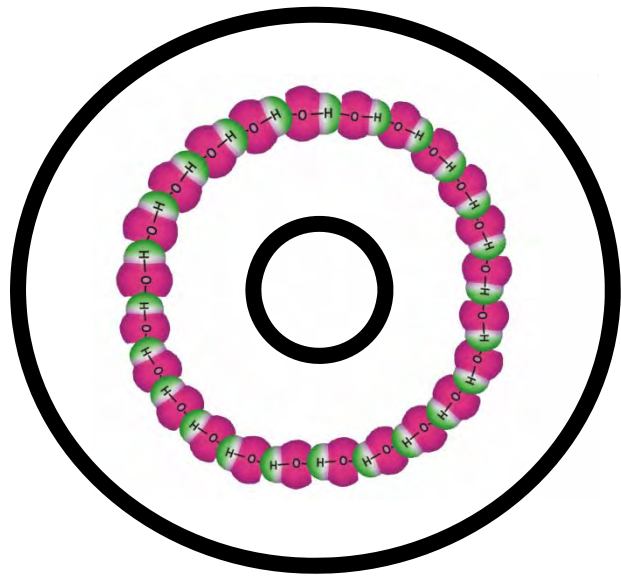

Water Crystal Ring

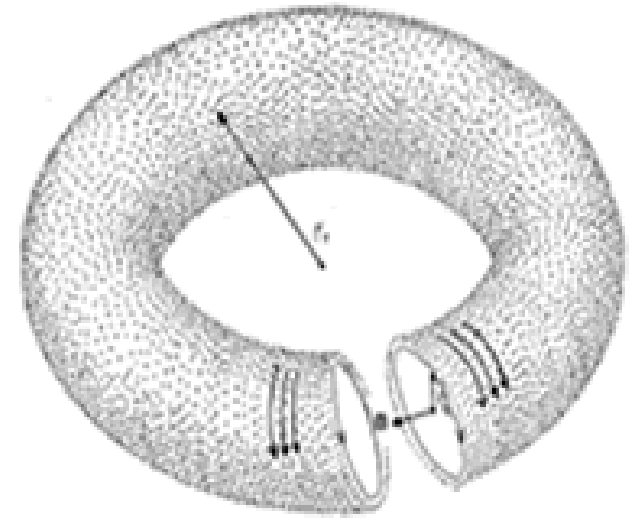
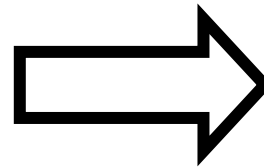

Plasmoid



How to Cavitate



How to Cavitate

- Electrolysis Gas in tight gaps
- Venturi Vacuum
- Blow Air through Gaps
- Oscillate Electric Field, PWM
- Vibrate Mechanically
- Sonic, Ultrasonic
- Cavitating Pumps, Vortex Action



How to Cavitate

Electrolysis Gas in Narrow Gaps

Electrodes Have Rough Surface

Paul Zigouras



Electrolyzer

<http://www.panacea-bocaf.org/paulzigouras.htm>

Zigouras Electrodes

Paul Zigouras

Electrolytic cell

12VDC - 30KHz - 100Amp

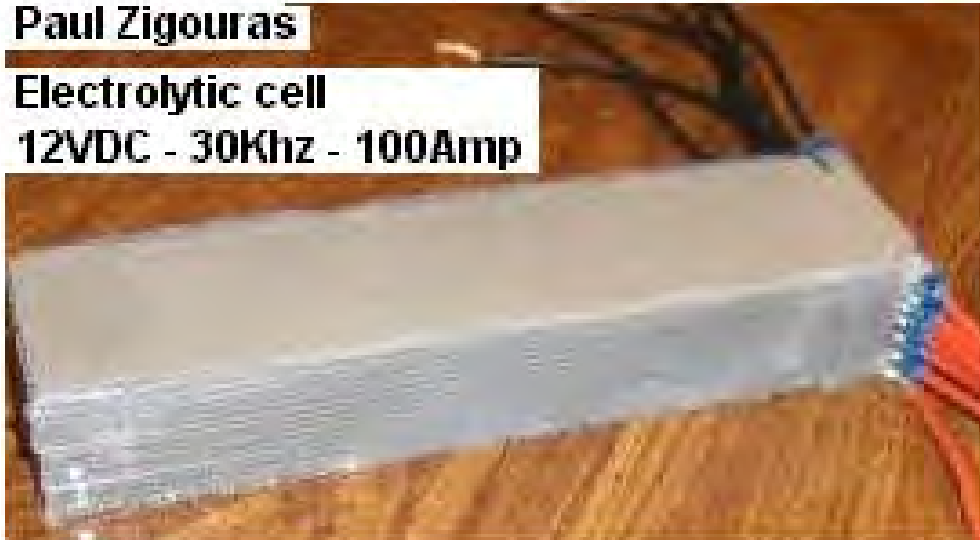

316L Stainless Steel Plates

Spacing 0.6 mm

<http://essenceciel.tk.free.fr/phpBB2/viewtopic.php?t=420>



Zigouras Sand Blasting

45 Degree Angle

40 – 45 Grit
Silicon Carbide

Makes Barbed
Sharp Edge Craters

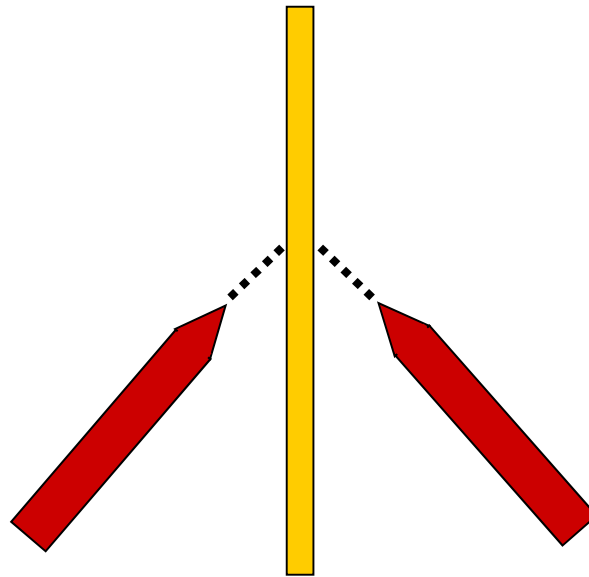

316L Stainless Steel Plate



Zigouras Media Blaster





Zigouras Electrodes



[Play](#)

Walter McNichols

<http://www.youtube.com/watch?v=dkT9TpdIVzs>

Vacuum of Venturi Feed

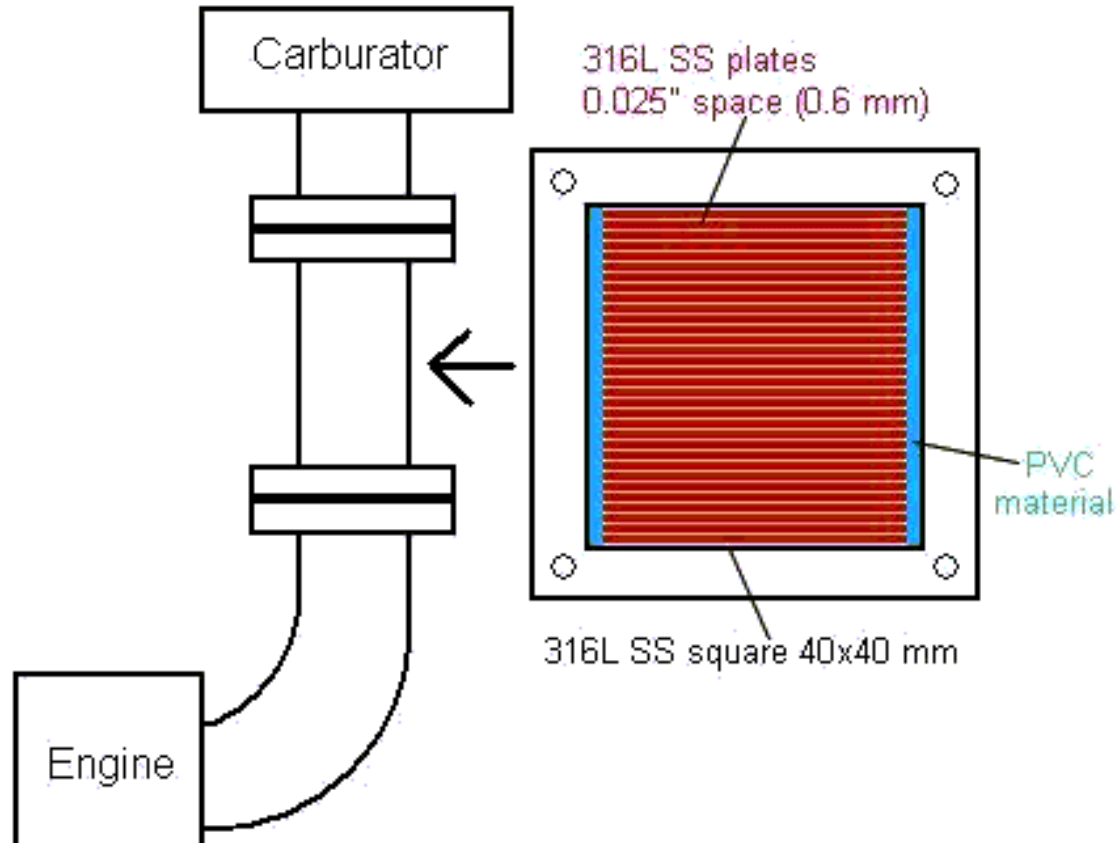



How to Cavitate

Blow Air Through Gaps



Archie Blue

U.S. Patent 4,124,463 (1978)

Blow air through electrolyzer

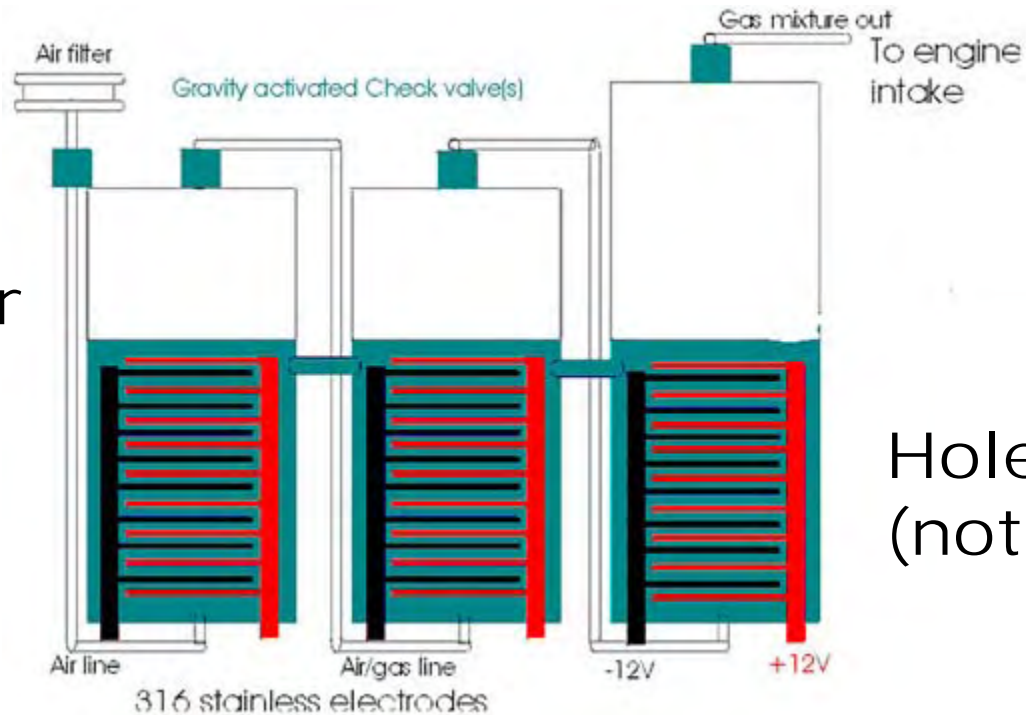

Holes in plates (not shown)

Peter Lowrie

<http://waterpoweredcar.com/archieblue.html>



How to Cavitate

Mechanical Vibration

Ohmasa Gas



Torch



Runs Engine

Mechanical Vibration 100 Hz

Parallel Plate Electrolyzer

Stored gas under pressure, 2 years

Ohmasa Gas



[Play](#)

<http://www.youtube.com/watch?v=NUPE0Z9V82E>



How to Cavitate

Oscillating Electric Field



Xogen Power, Inc. Xogen Technologies, Inc.



<http://www.xogen.ca>

Stephen Barrie Chambers

(12) **United States Patent**
Chambers

(10) **Patent No.:** US 6,790,324 B2
(45) **Date of Patent:** Sep. 14, 2004

(54) **HYDROGEN PRODUCING APPARATUS**

(75) **Inventor:** Stephen Barrie Chambers, Calgary (CA)

(73) **Assignee:** Xogen Power Inc., Calgary (CA)

(*) **Notice:** Subject to any disclaimer, the term of this patent is extended or adjusted under 35 U.S.C. 154(b) by 207 days.

(21) **Appl. No.:** 10/180,855

(22) **Filed:** Jan. 25, 2002

(65) **Prior Publication Data**

US 2002/0079453 A1 Dec. 5, 2002

Related U.S. Application Data

(63) **Continuation of application No. 09/608,316, filed on Jan. 30, 2000, now Pat. No. 6,419,815, which is a continuation of application No. 09/115/023, filed on Jan. 26, 1998, now Pat. No. 6,126,794.**

(51) **Int. Cl.⁷** C28D 17/00

(52) **U.S. Cl.** 204/242; 204/267; 204/272; 204/276; 204/293; 204/278.5

(58) **Field of Search** 204/242, 267, 204/293, 278, 272, 278.1; 205/028-032

(50) **References Cited**

U.S. PATENT DOCUMENTS

3,311,097 A 3/1967 Mikolajchik 128/139
3,654,592 A * 5/1976 Eberath 204/228.7
4,187,008 A * 8/1979 Eberath 205/034
4,184,931 A 1/1980 Ison 204/129
4,339,787 A 2/1982 Thoms 204/242
4,384,280 A * 7/1983 Puharch 205/041

4,590,158 A 7/1986 Ofenloch 204/228
4,750,661 A 1/1989 Meyer 204/228
5,338,621 A * 8/1994 Abu et al. 204/504
5,632,870 A 5/1997 Kosharev 204/241

FOREIGN PATENT DOCUMENTS

JP 9071980 5/1997 C29B3/04
RU 2 048 089 C1 11/1995 C29B3/04
WO 9809001 5/1998 C29B3/04

* cited by examiner

Primary Examiner—Donald R. Valentine
(74) **Attorney, Agent, or Firm**—Stoel Rives LLP

(57) **ABSTRACT**

An apparatus for producing orthohydrogen and/or parahydrogen. The apparatus includes a container holding water and at least one pair of closely-spaced electrodes arranged within the container and submerged in the water. A first power supply provides a particular first pulsed signal to the electrodes. A coil may also be arranged within the container and submerged in the water if the production of parahydrogen is also required. A second power supply provides a second pulsed signal to the coil through a switch to apply energy to the water. When the second power supply is disconnected from the coil by the switch and only the electrodes receive a pulsed signal, then orthohydrogen can be produced. When the second power supply is connected to the coil and both the electrodes and coil receive pulsed signals, then the first and second pulsed signals can be controlled to produce parahydrogen. The container is self-purged and the water within the container requires no chemical catalyst to efficiently produce the orthohydrogen and/or parahydrogen. Heat is not generated, and bubbles do not form on the electrodes.

16 Claims, 10 Drawing Sheets

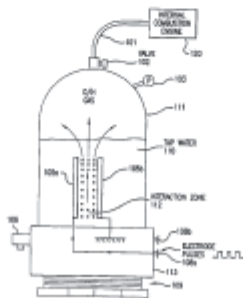

U.S. Patents:

6,126,794 (2000)

6,419,815 (2002)

6,790,324 (2004)

Xogen Power Inc.



Toroidal Coil

Under Water
1500 turns
19 Hz

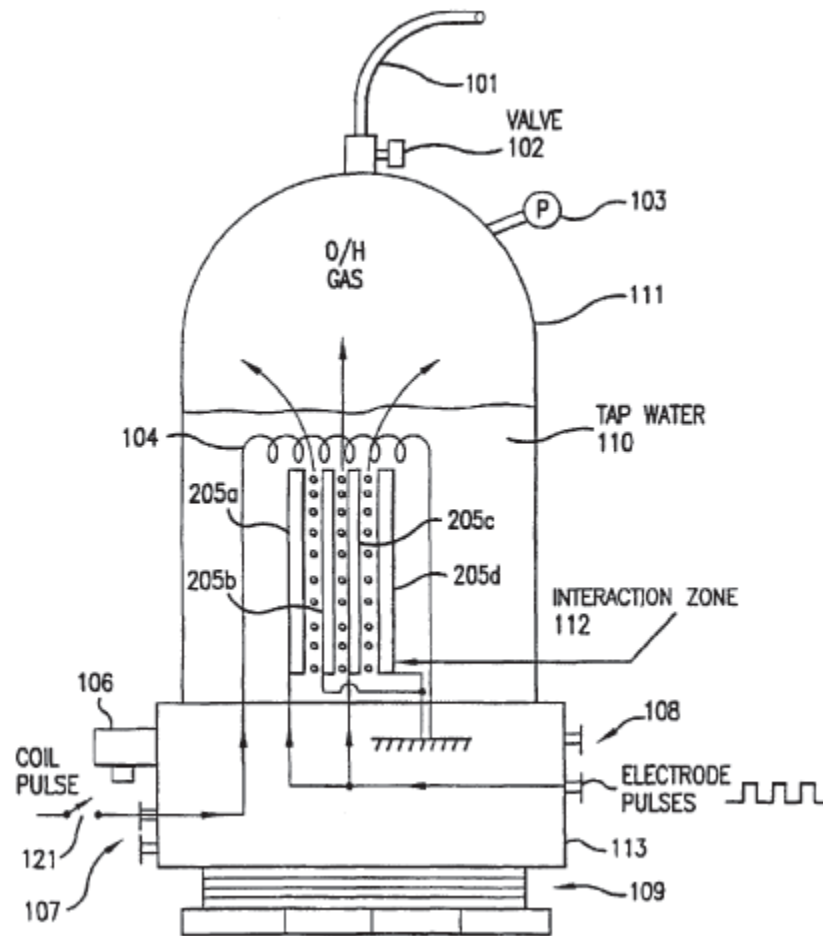

Fig 7

Chambers, US Patent 6,790,324 (2004)



Induced Electric Field

$$\mathbf{E} = - \frac{\partial \mathbf{A}}{\partial t}$$

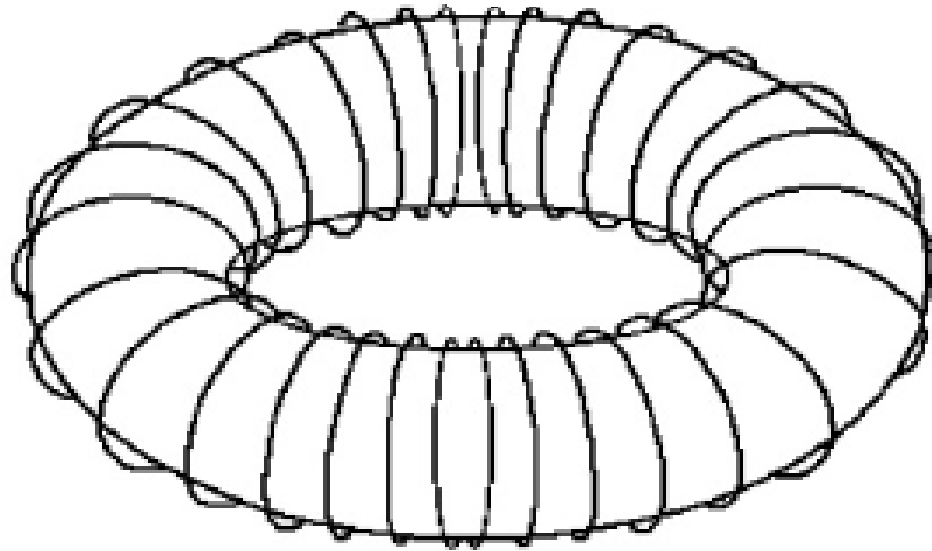

Charge water clusters oscillate with E field

Causes turbulence in water



How to Cavitate

Sonic, Ultrasonic Vibrations

Freddy Wells

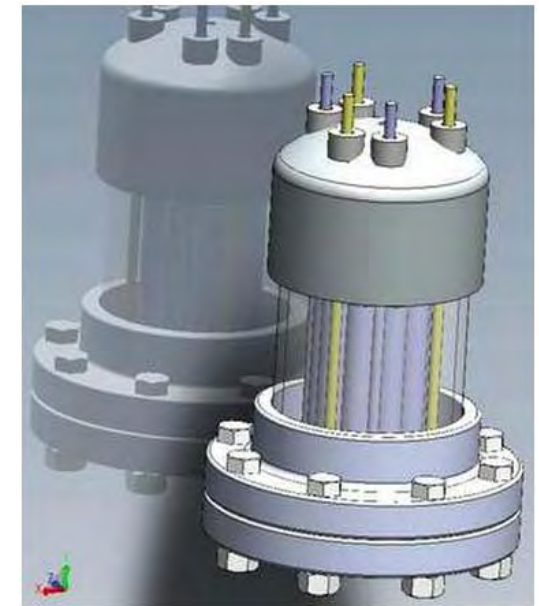
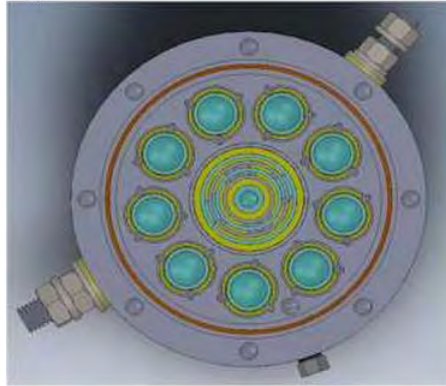

**Vibrate Pipe Electrodes
Acoustically**

**Inner & Outer Pipes Tuned
Identically**

Ran 2004 Dodge Truck

<http://peswiki.com/index.php/Directory: Hydrogen Hog by Future Energy Concepts, Inc.>



How to Cavitate

Cavitating Pumps

Vortex Implosion

James Griggs Hydrosonic Pump

Water Heater
Overly Efficient
130%

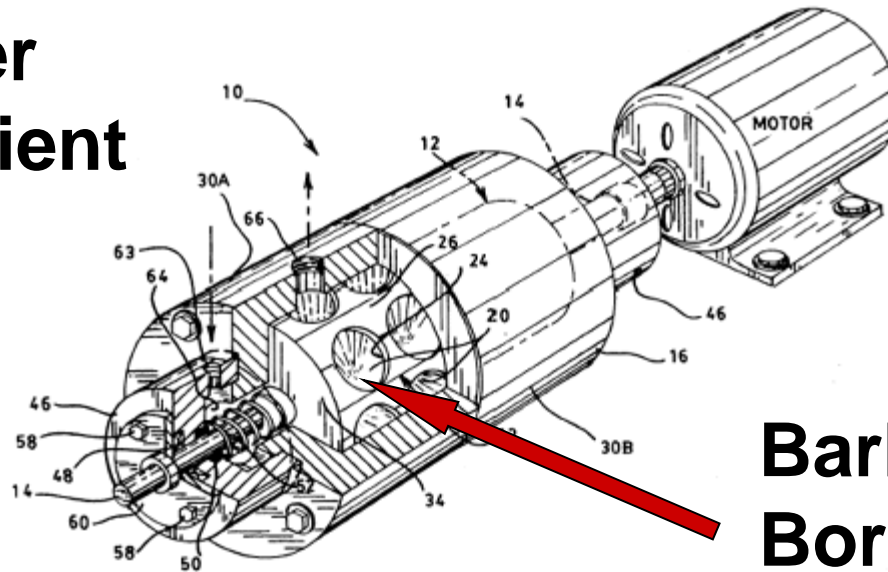

**Barbed Edge
Bore Holes Cause
Cavitation**

U.S. Patent 5,188,090 (1993)

<http://www.rexresearch.com/griggs/griggs.htm>



John W Keely

Hydro Vacuo Engine



Patent Filed 1872

Based on **Water Hammer**

**Bulbs are Pulsating
Chambers**

Dale Pond <http://www.svpvril.com/JKMot2.html>

Viktor Schauberger



1885 - 1958

Water Jet Turbine

Austrian Patent 117,749 (1930)

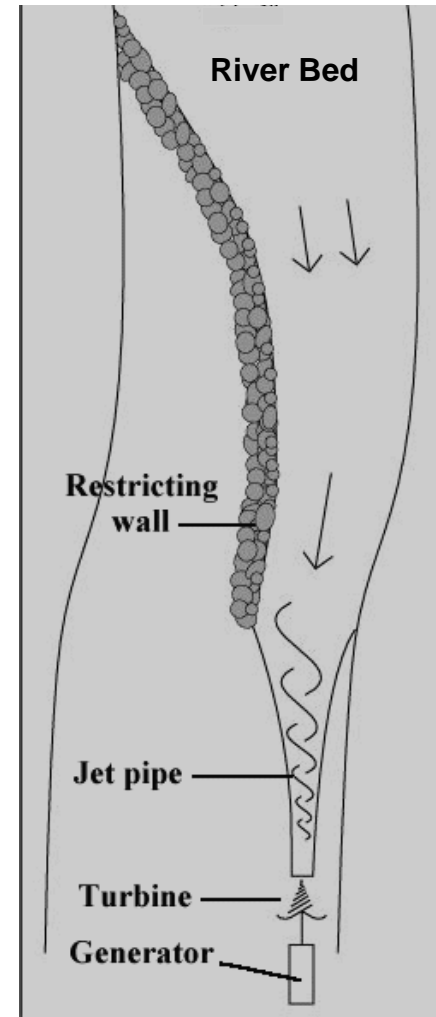
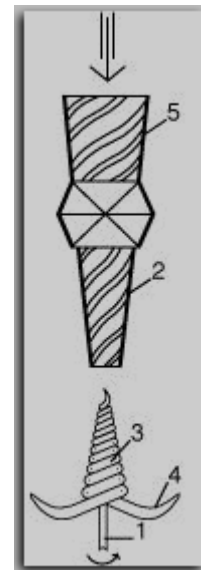

Richard Clem Engine

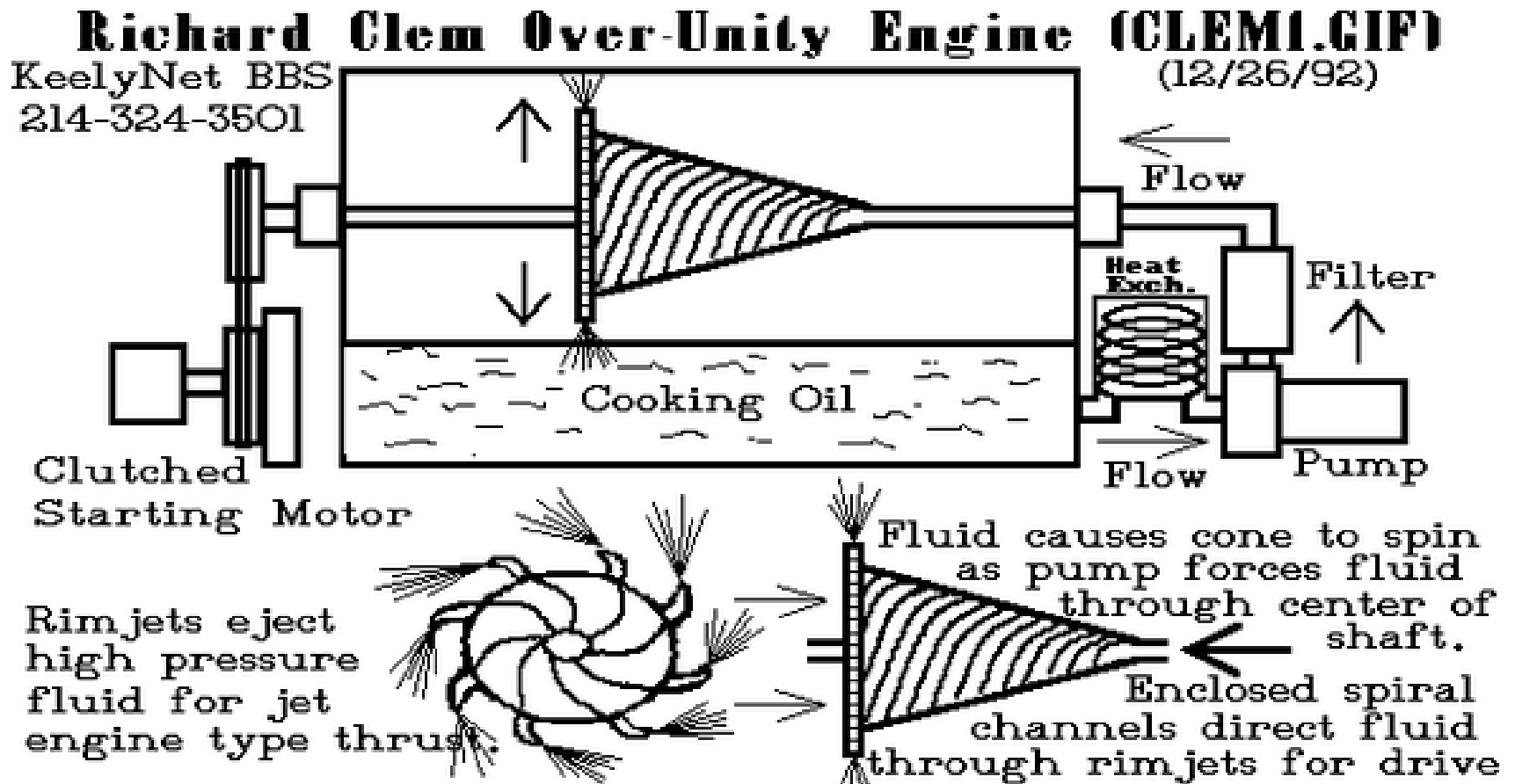

<http://keelynet.com/energy/clem1.htm>

Vortex Imploder



Dan Winter

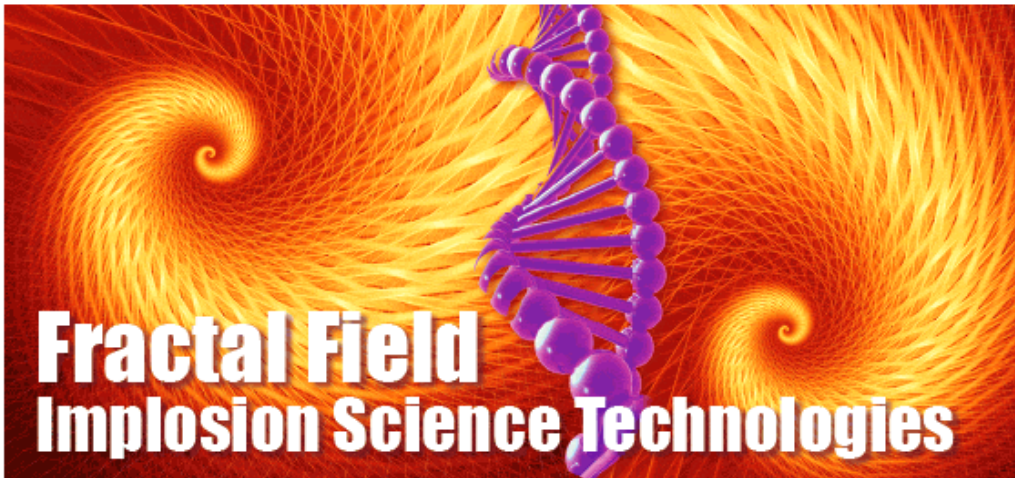

<http://www.fractalfield.com/>

<http://theimploder.com/products/imploder-shower-nozzle>





Biokavitus (Bio Cavitation)

Andrea Rampado

Enhanced Plant Growth

Water Purification

Separate Oil from Water

Nuclear Remediation

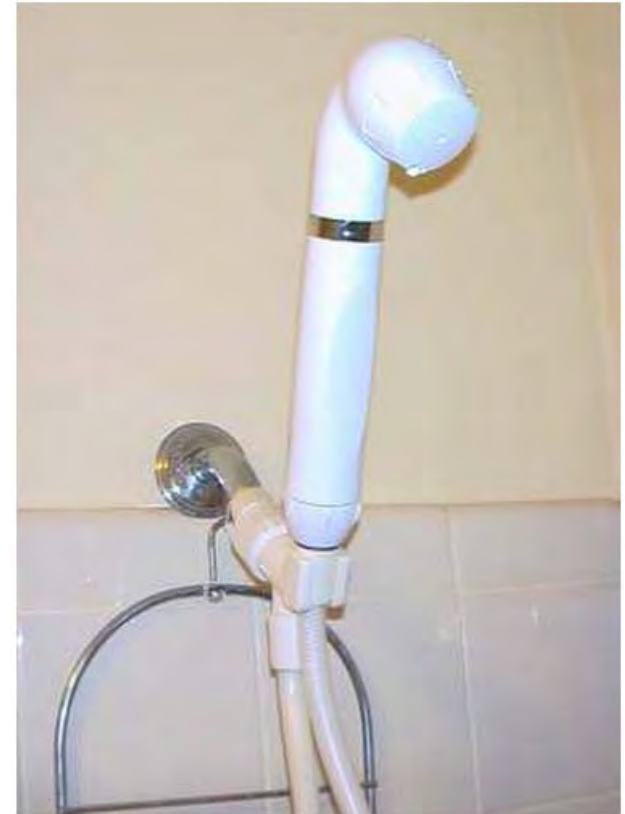

Venturi Shower Head

Sterling Allan

[http://pesn.com/2011/11/05/9501947_Cavitation
as_a_Purification_Panacea/](http://pesn.com/2011/11/05/9501947_Cavitation_as_a_Purification_Panacea/)



Circulate Water

To Both Cavitate It

And Charge It by

Electrostatic Rubbing



T.V. Prevenslik

Bubbles and Steam Electricity

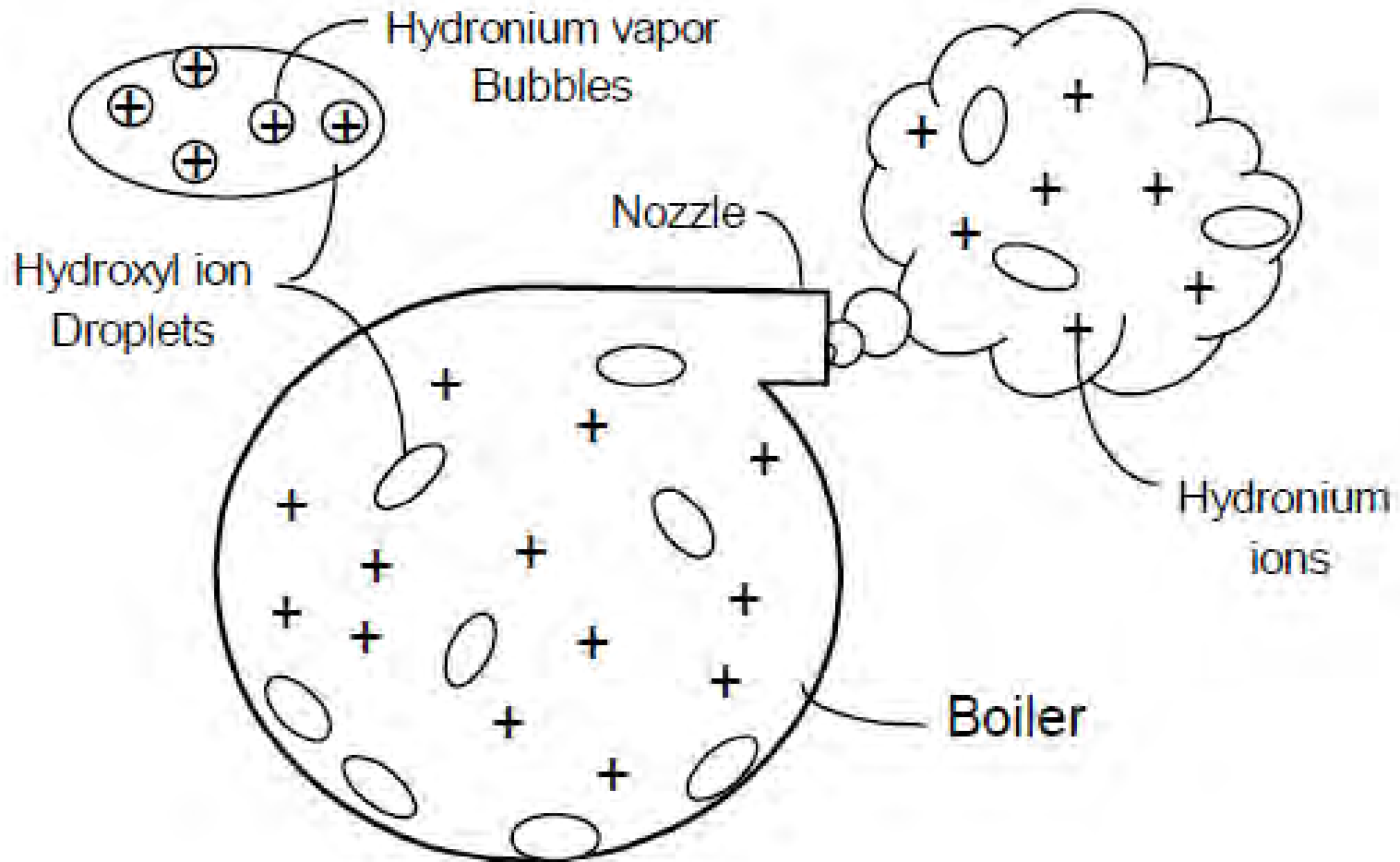



T.V. Prevenslik

Bubbles and Steam Electricity

- Steam Electricity
- Waterfall Ionization
- Sonoluminescence
- Thunder Cloud Charge Separation

<http://www.esdjournal.com/techpapr/prevens/previndx.htm>

Thundercloud Dynamics

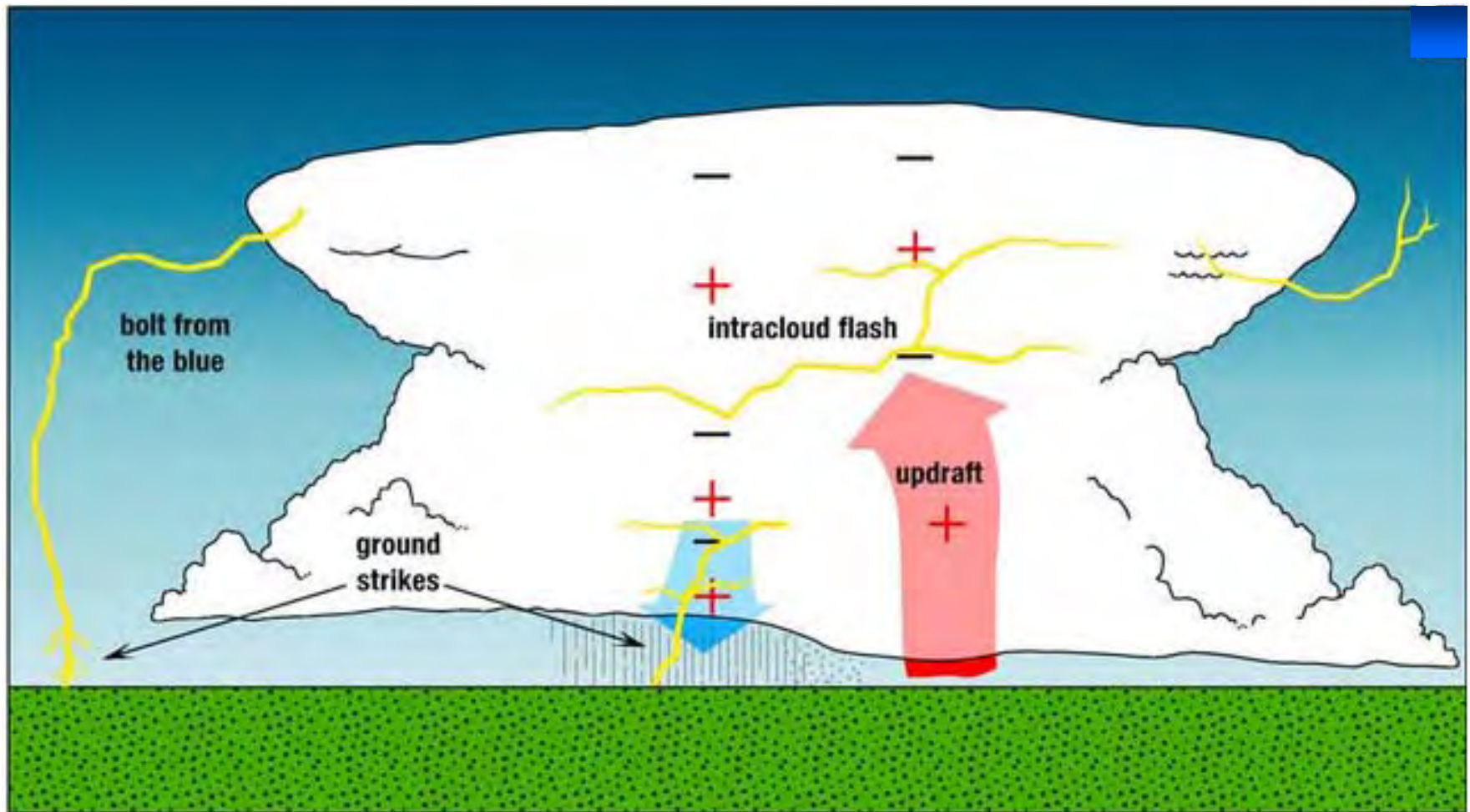

http://www.nssl.noaa.gov/primer/lightning/ltg_basics.html



Van de Graaff Generator

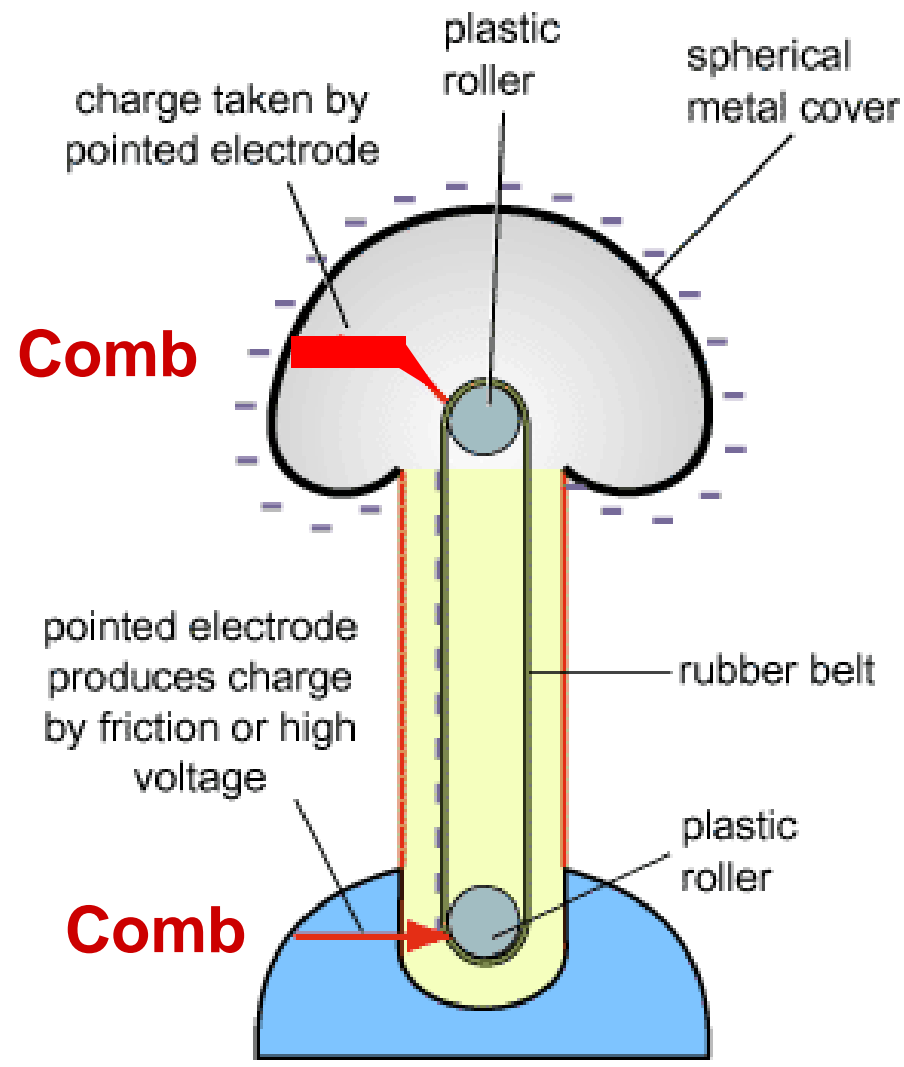



Circulating Water Electrolyzer Like Van de Graaff Generator

- Distilled water acts as dielectric belt
- Rough conductive plates act as combs



Water Turbulence Flow Across Bottom

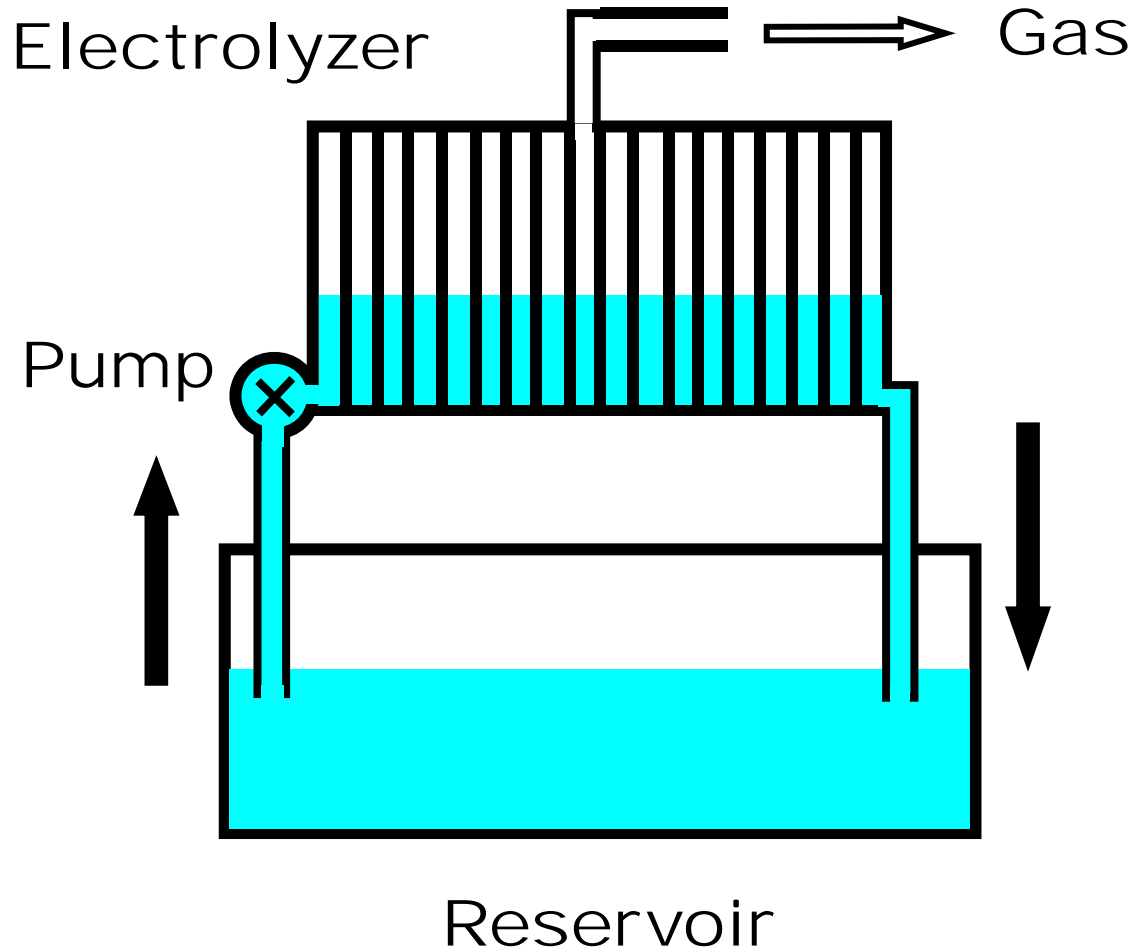



Rapidly Circulate Water





Reed Cavitation

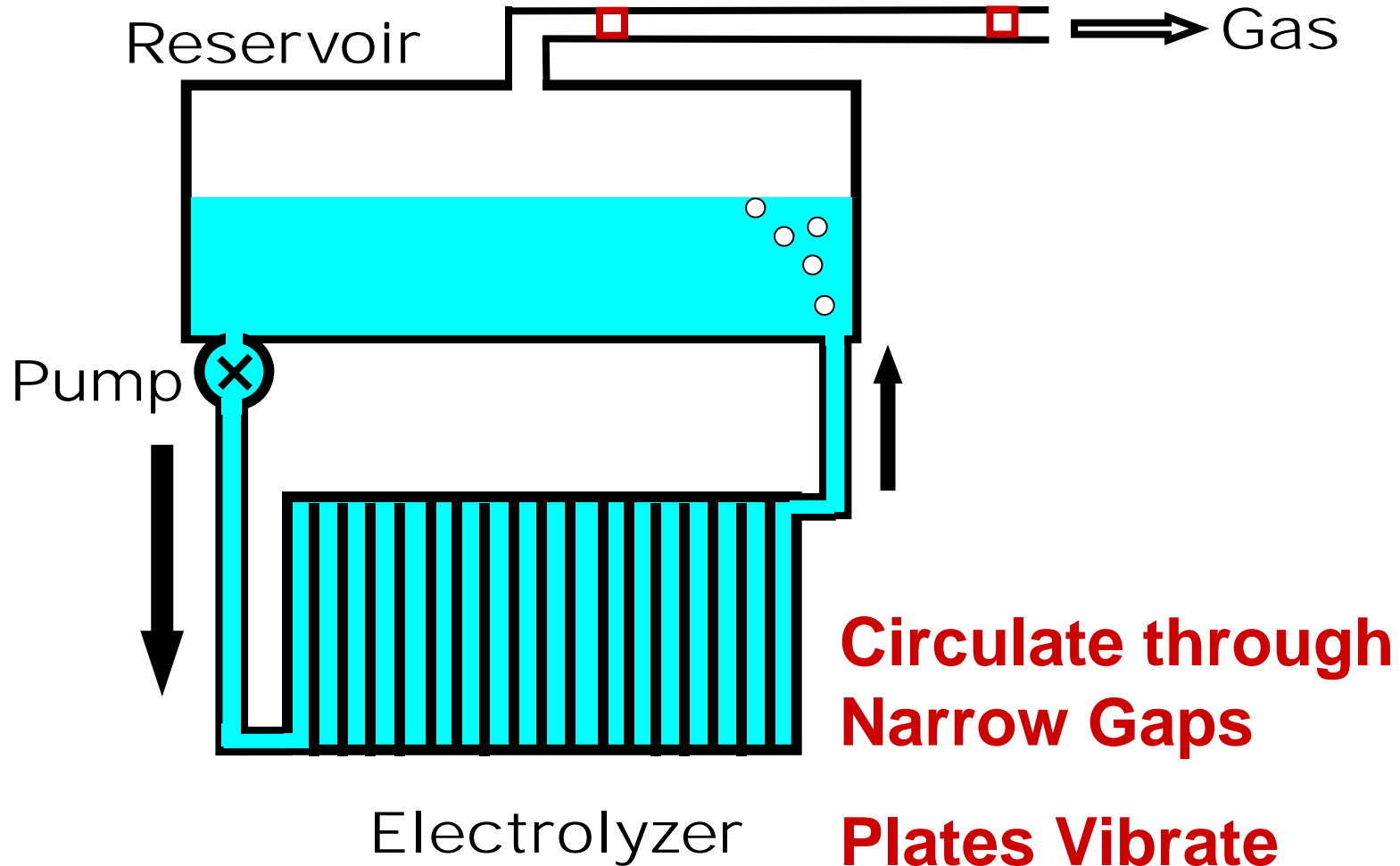



Goal:

Make Self-Running System

Prove New Energy Source



Closed Loop System

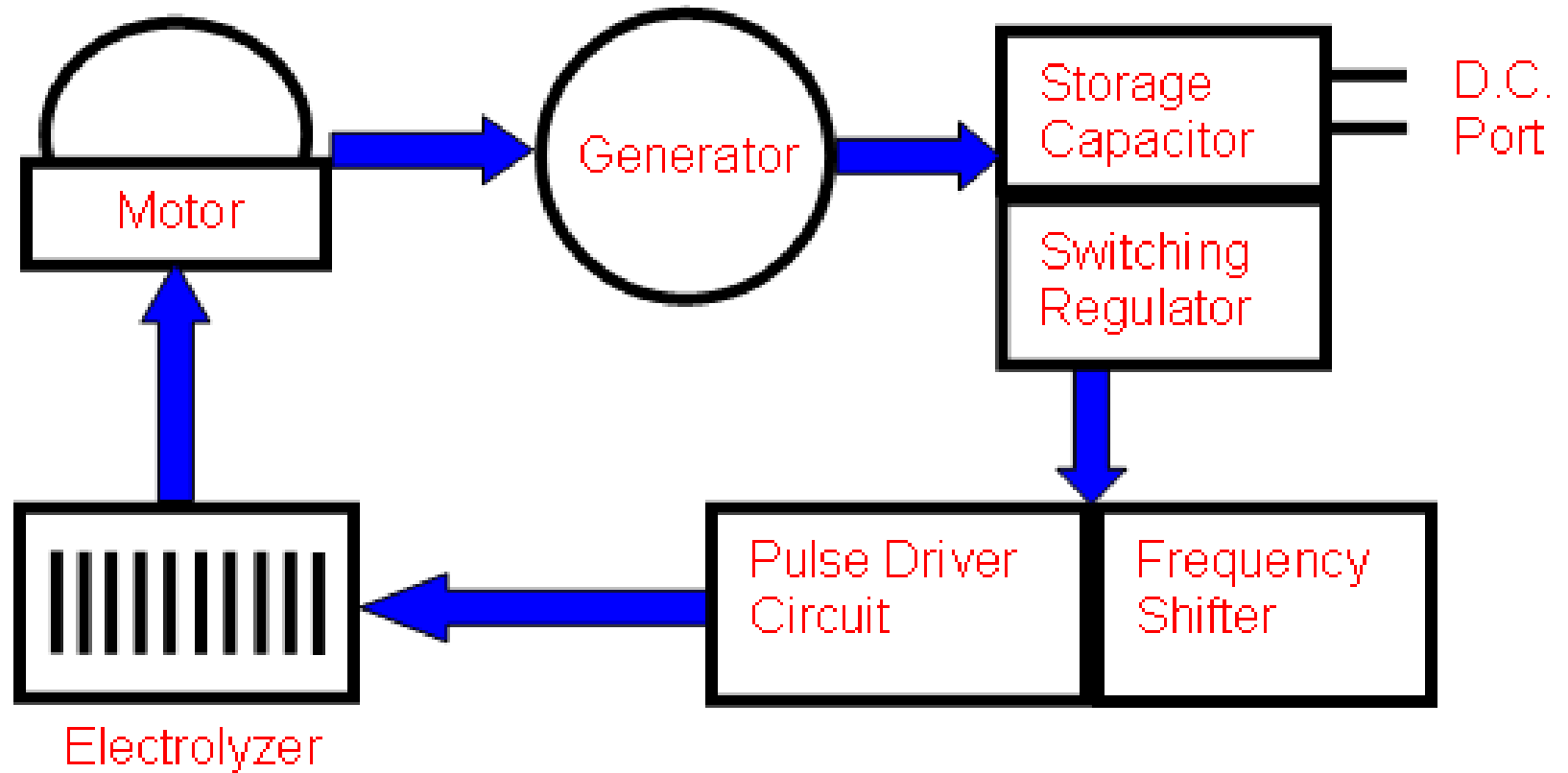

Self Running



Action Item: Inventors

- Make Closed-Loop, Self-Running System
- Prove Discovery of New Energy Source
- Share Information on Web



Two Teams Succeeded

HybridTech Releases Plans

3.25 KW Troy-Bilt Generator

Self-running for 20 minutes

6 liters/minute HHO

12.5 V DC 30 amps

Extra loads:

Light bulbs

Power drill



http://pesn.com/2009/11/13/9501586_HybridTech-Energy_releases_water-fuel_generator_plans/

Steven Eaton

Concentric Cylinder Electrodes



6 inches high 1/2 inch outer 3/8 inch inner
1/32 inch gap

Sokol, *You Can Turn Water into Fire*, p 90

Eaton Cell Wiring

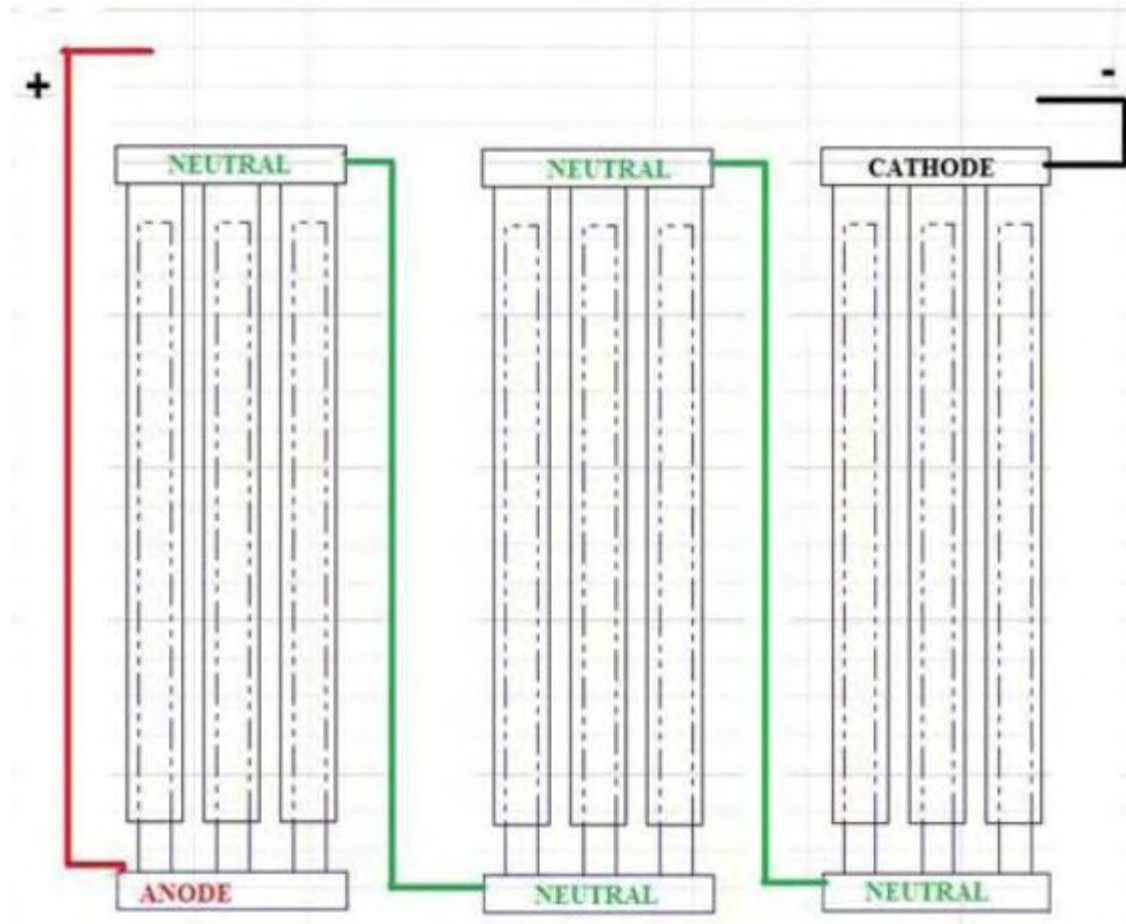

Sokol, *You Can Turn Water into Fire*, p 81



Eaton Cell

Concentric Cylinder Electrodes



1/32 inch gap

Sokol, *You Can Turn Water into Fire*, p 87



Eaton Cell

Spiral Monofilament Line



Can induce vortex flow

Sokol, *You Can Turn Water into Fire*, p 87



Eaton's Large Cell

16 inches



Sokol, *You Can Turn Water into Fire*, p 96

Eaton Cells



16 inch

6 inch

Oliver & Valentin

Closed-Loop, Self-Running, HHO System

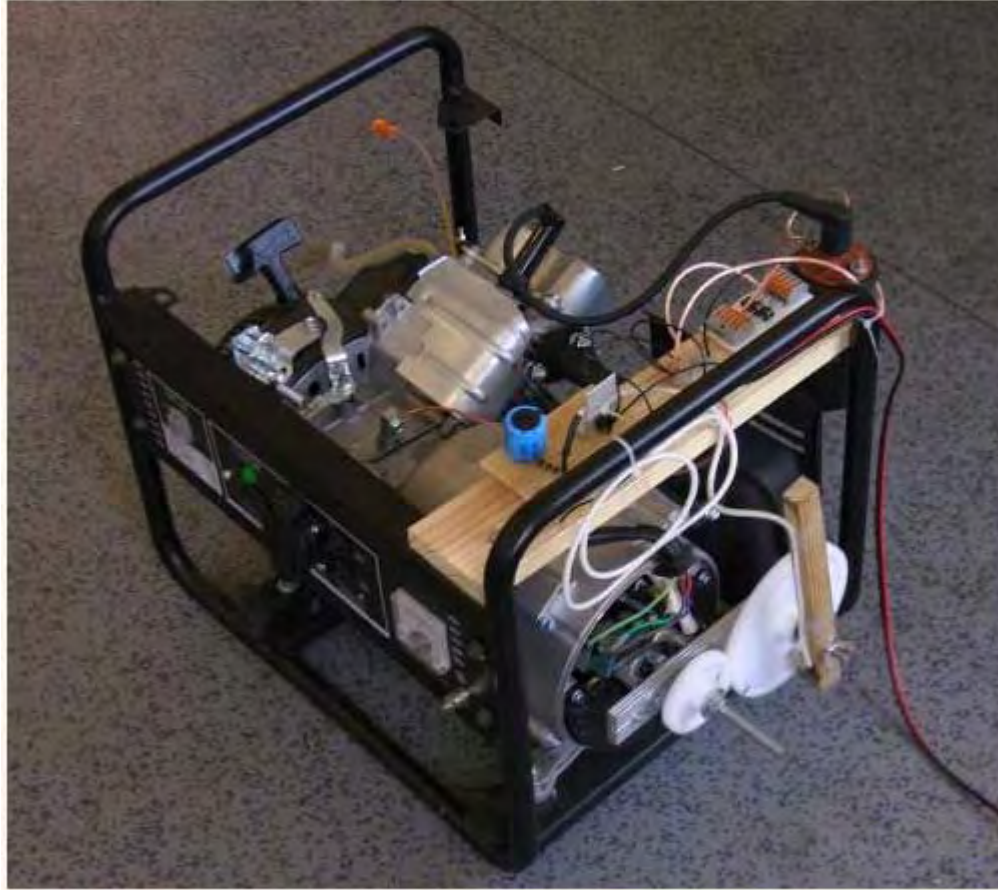

http://peswiki.com/index.php/OS:Self-Looped_Anton_HHO_Cell_System



Anton Cell

1 mm
Gap



<http://anton-shop.com/>

Oliver & Valentin

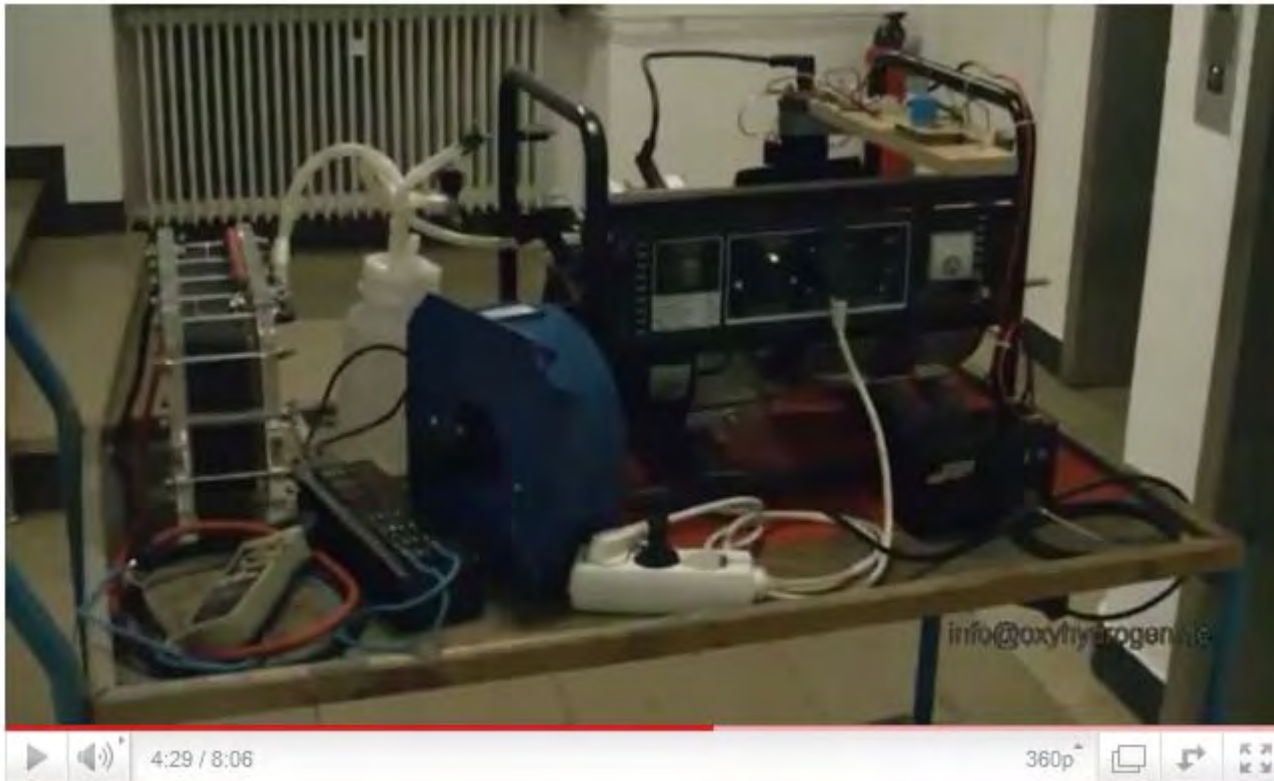

Self-running for 8 minutes

Rode on elevator

http://www.youtube.com/watch?v=cMlciNOyo_U



Oliver & Valentin Finale



[Play](#)

Stefan Hartmann

<http://www.youtube.com/watch?v=uQ9fyam4whg>



Summary



Summary: Electrolyzer

- **Electrodes**
 - **Rough, Clean Surface**
 - **Small Gaps (< 1mm)**
 - **Causes Turbulence, Cavitation**

- **Electrical Stimulation**
 - **Pulsed Waveforms**
 - **Minimize Current and Electrolyte**
 - **Frictional Rubbing via Circulation**



Summary: Cavitation

- **Bubble Collapses**
- **Reentrant Jet**
- **Water Crystal**
- **Closed Rings**
- **Stable Torus**
- **Coherent Energy**
- **LeClair Effect**

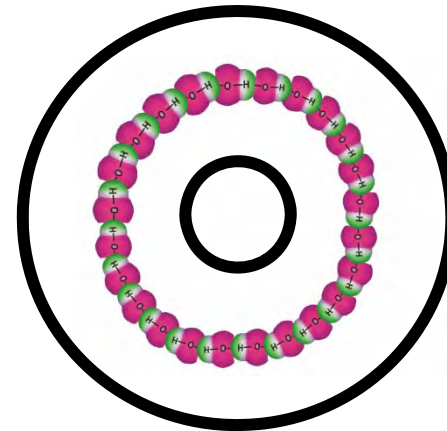



Summary: How to Cavitate

- **Electrolysis Gas in Narrow Gap**
- **Blow Air**
- **Venturi Vacuum**
- **Vibrations**
 - **Mechanical**
 - **Acoustical: Sonic, Ultrasonic**
 - **Oscillate Electric Field**
 - **Toroidal Coil**
 - **Pulsed Waveform**



Summary: Circulation

- **Water Charged by Rubbing**
- **Turbulence, Cavitation**
- **Vibrate Plates: Reed Cavitation**
- **Recycling Water Integrates Energy Content**



Action Items

- **Chemistry Departments:**
 - Make Brown's Gas --- Remove Hydrogen
 - What is the water cluster gas?
- **Physics Departments:**
 - Repeat LeClair's Transmutation Experiment
 - Measure Isotopes
- **Inventors:**
 - Make Self-Running Systems
 - Electrolyzer -- Generators



Share Information

Make A New World



Cavitation Bubble Collapses into Torus



An Archetype Form

Thrive Movement



[Play](#)

<http://www.thrivemovement.com/>



Quest For Zero Point Energy

Engineering Principles
For "Free Energy"

Moray B. King

Tapping The Zero-Point Energy



How "Free Energy" and "Anti-Gravity"
Might Be Possible with Today's Physics

Moray B. King



THE ENERGY MACHINE OF T. HENRY MORAY



Zero-Point Energy &
Pulsed Plasma Physics

Moray B. King

<http://www.AdventuresUnlimitedPress.com>



Questions?

Download this presentation from

[http://peswiki.com/index.php/Video:Water as Fuel \(via ZPE\)](http://peswiki.com/index.php/Video:Water_as_Fuel_(via_ZPE))

Google: **Water Fuel ZPE**